

Feasibility Report

Rampton to Cottenham Cycleway

May 2023

Document History

JOB NUMBER: 5020600			DOC REF: 5020600/300/320			
P01	First Issue	HL	STE	OJB	OJB	05.05.23
Revision	Purpose Description	Originated	Checked	Reviewed	Authorised	Date

Printed copies of this document are not controlled. The master document is controlled electronically. Document users are responsible for ensuring printed copies are valid prior to use.

Contents

Section	Page
Contents	2
Executive Summary	3
1.0 Introduction	3
2.0 Site Characteristics	4
3.0 Design Criteria	4
3.1 Drainage	5
3.2 Construction Site and Access	5
3.3 Ecology and the Environment	6
3.4 Health and Safety	6
3.5 Third Parties & Technical Approvals	6
3.6 Structures	7
3.7 Geotechnical	7
3.8 Ecological	7
3.9 Utilities	7
3.10 Site Constraints	8
4.0 Alignment Options	8
4.1 Option 1	9
4.1.1 Cycleway / Footway Design	9
4.1.2 Structures Design	9
4.2 Option 2	10
4.2.1 Cycleway / Footway Design	10
4.2.2 Structures Design	11
4.3 Option Assessment	13
4.3.1 Cycleway / Footway Design	13
4.3.2 Structures Design	14
5.0 Cost Estimate	18
6.0 Conclusion	19
Appendix 1 - Rampton to Cottenham Cycle Counts	20
Appendix 2 – Highways Drawings	21
Appendix 3 – Structures Drawings	22
Appendix 4 – Design Environmental Assessment	23

Executive Summary

This Report was commissioned by Cambridgeshire County Council to investigate Options for a new combined pedestrian and cycle path between Rampton and Cottenham.

The Report identifies two main routes to be considered.

- Option 1 is for an online route running parallel to Rampton Rd separated by a 2.5m verge
- Option 2 is for an offline route with the new cycle path running behind the existing hedge line beside Rampton Rd.

Consideration is given to the constraints and opportunities for the project including land ownership, the cycleway design criteria, environment & ecology, third parties and technical approvals, as well as provisional cost estimates based on the Option drawings.

From a cost and engineering perspective it is advised Option 2 to be the most feasible. Option 2 is compliant with LTN1/20, has the smallest impact on existing ecology, and typically it is easier to construct new structures than modify existing ones.

A third Option has been considered which is a hybrid between Option 1 and 2. Essentially, where land could be purchased the new path would be constructed offline, and where land could not be attained then the route returns online. This option would be preferable if landowners are unwilling to sell the land required for the scheme.

1.0 Introduction

Presently, the pedestrian/cycling facilities linking Rampton with Cottenham are inadequate, with widths limited to 1.5-2m, and a lack of separation between the footway and carriageway.

This Report will undertake an assessment for a new hardened shared cycleway/footway which will commence where Cow Ln joins High St (Rampton) and terminates at Ramphill Farm, Rampton Rd. For the site overview refer to Figure 1.

2.0 Site Characteristics

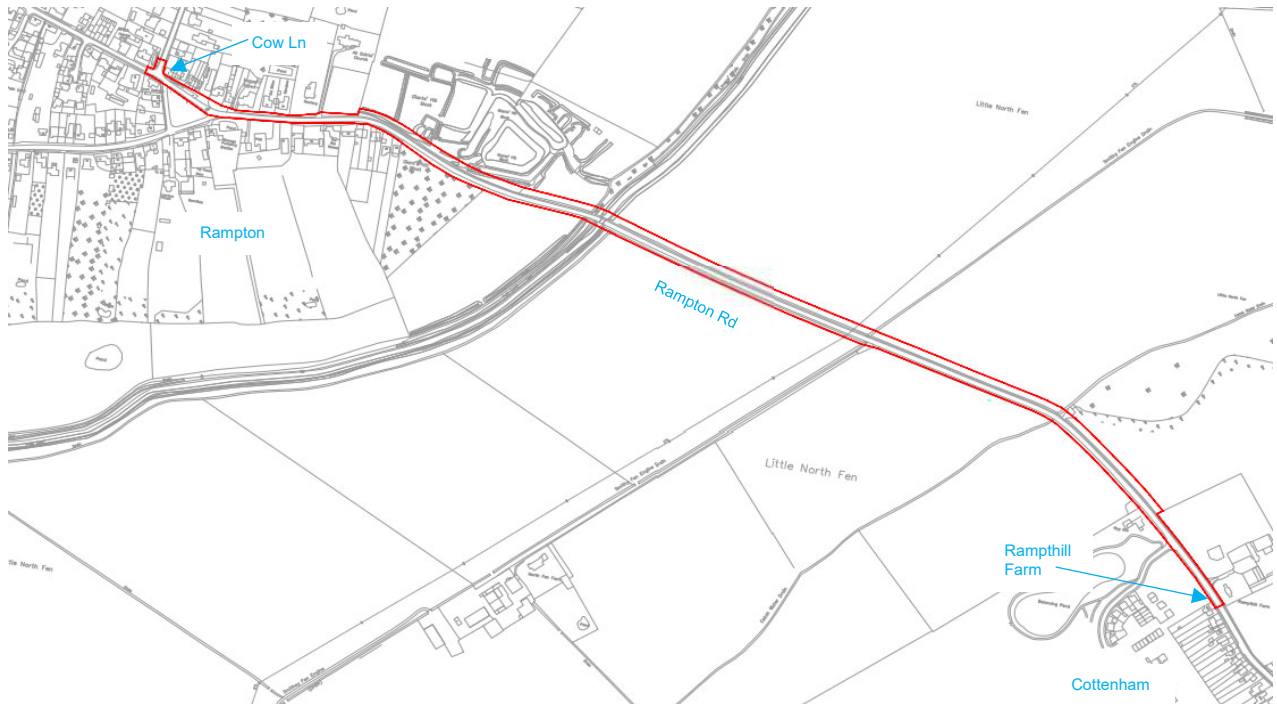

Figure 1: Site Overview

The site is made up of large, low-lying, flat landscape with several drainage ditches, dykes and rivers. The adjacent land use is predominantly arable. Open fields, bounded by a network of drains and the distinctive hierarchy of rivers (some embanked), have a strong influence on the geometric/rectilinear landscape pattern

3.0 Design Criteria

LTN 1/20: Cycle Infrastructure has been used as the design criteria for developing the Options. The main criteria are as follows.

- Chapter 5, table 5-2: Cycle Lane & path widths
- Chapter 5, table 5-7: Minimum horizontal radii – recommended minimum 4m for cyclists
- Chapter 6, table 6-1: Minimum recommended horizontal separation between carriageway & cycle paths.

LTN 1/20 Table 5-2 below provides guidance on minimum widths for cycling facilities and determines the peak hour cycle flow. Cycle counts, undertaken as part of this study, found that less than 300 cyclists used the existing facility per day. It is expected that any new facility would encourage more walking and cycling, therefore we have assumed typical cycle flow will be less than 300 per hour. Therefore, a 3.0m desirable minimum width is recommended with 2.0m being the absolute minimum at constraints.

Cycle Route Type	Direction	Peak hour cycle flow (either one way or two-way depending on cycle route type)	Desirable minimum width* (m)	Absolute minimum at constraints (m)
Protected space for cycling (including light segregation, stepped cycle track, kerbed cycle track)	1 way	<200	2.0	1.5
		200-800	2.2	2.0
		>800	2.5	2.0
	2 way	<300	3.0	2.0

Table 1: LTN 1/20 Table 5-2

Printed copies of this document are not controlled. The master document is controlled electronically. Document users are responsible for ensuring printed copies are valid prior to use.

Table 6-1 taken from LTN 1/20 confirms desirable widths for separation strips between the carriageway and cycleway. For this site, the speed limit is 60mph, therefore a minimum 2.5m desirable minimum width should be provided, with 2.0m being the absolute minimum. Consideration could be given to reducing the speed limit on Rampton Road to achieve better compliance and reduce the required horizontal separation.

Speed limit (mph)	Desirable minimum horizontal separation (m)	Absolute minimum horizontal separation (m)
30	0.5	0
40	1.0	0.5
50	2.0	1.5
60	2.5	2.0
70	3.5	3.0

Table 2: LTN 1/20 Table 6-1

The existing facility is non-compliant with LTN 1/20, due to paths widths less than the 3.0m desirable width, and only a 0.5m separation strip. We have therefore assumed in all Options that the existing path is to be broken out and returned to verge.

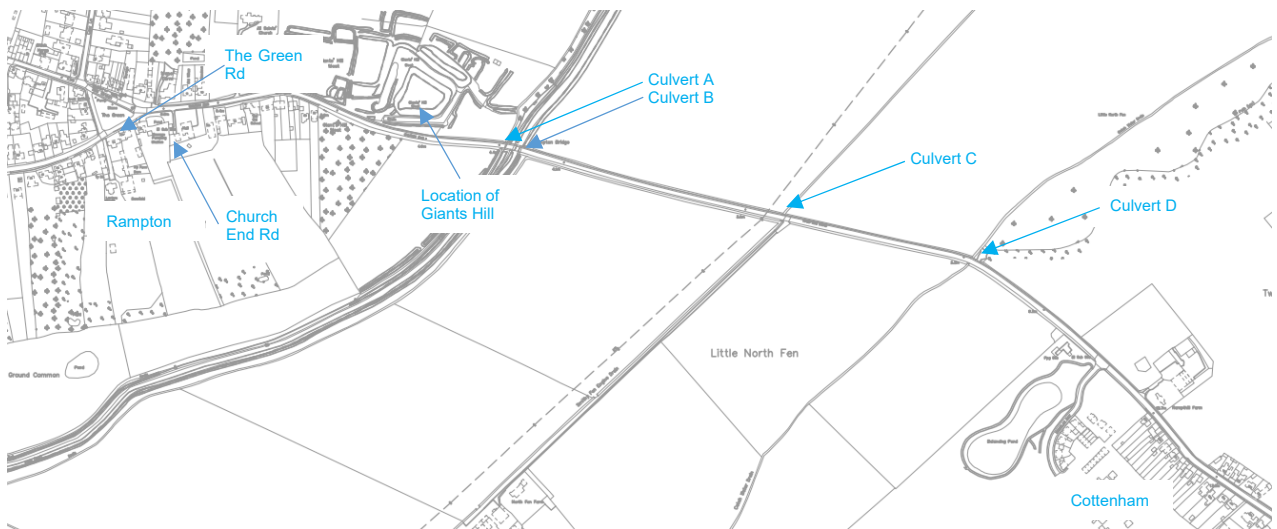

Figure 2: Structure Location Plan

3.1 Drainage

Much of the area between Culvert A & D will be over edge drainage, however where the reduction in carriageway width occurs, the facility will drain into new / existing road gullies. Crossfalls at the start and end of both Options will replicate existing footway crossfalls, or property boundaries.

Potential issues with Culverts are that they become clogged with debris, which can cause problems with drainage and eventually lead to flooding. The design of the extensions has taken this into account; the extensions will match the water way areas provided by the existing structures to ensure the flow of the watercourse is unaffected. Correspondence and approval with the relevant drainage authorities for each structure will be obtained prior to the design phase. Any required consents will be in place for before works commence and any conditions/constraints/mitigations that arise from these will be followed during the works.

3.2 Construction Site and Access

Currently, there is no direct vehicle access leading to any of the offline routes. Due to the linear nature of any route through the fields, it would need to be constructed in a linear method, which is costly and time consuming – even if approached from each end. Additionally, there are further site constraints in relation to the existing drainage ditches. Any Option constructed online would require long periods of traffic

Printed copies of this document are not controlled. The master document is controlled electronically. Document users are responsible for ensuring printed copies are valid prior to use.

management on Rampton Rd due to the narrower working widths. The offline Option has the potential of requiring no traffic management in some sections.

There are existing farm accesses along the proposed cycle route. One is just east of Culvert B; an alternate route would need to be devised for farm access during construction. The other is at Culvert D; this farm access will be considered when deciding which Option is best for the location. Sufficient access will be provided for farm access during construction.

Heavy vehicle and machinery will be present on the accesses to farmland. The new design at these locations will suit the greater load created from the heavy vehicles passing over.

3.3 Ecology and the Environment

Review of data provided by Environmental Agency England shows the site to be at a low risk of flooding, therefore a full flood risk assessment is not required.

The construction of any route could require the removal of suitable nesting habitat for common bird species. A full ecological survey would be required. Any constraints or mitigations that arise from the ecology walkovers shall be followed during the works. Option 1 requires the removal of an established hedge row; replanting where existing trees and hedges are to be removed will be required.

3.4 Health and Safety

Any offline route through agricultural plots would need to run alongside or cross deep ditches. Therefore, fencing requirements would need to be considered. Railing to the new wing walls is necessary providing it is a minimum height of 1.4m

There is currently no continuous street lighting on any route between Rampton and Cottenham. Any offline Option through agricultural land, except for solar studs, is unlikely to be lit due to the excessive light pollution. During darker hours, this would not just create security issues, but restrict the visibility for both pedestrians and cyclists and hence limit its usage.

3.5 Third Parties & Technical Approvals

Key third parties, stakeholders and landowners on the site are:

- Cambridgeshire County Council (CCC), South Cambridgeshire District Council, Cottenham District Council, and Rampton & Woodbeck Parish council. CCC are the client for this work and are also responsible for the maintenance of any future proposal.
- Landowners – Where land purchase is required, Liaison and negotiation with landowners should be undertaken first. Where possible, compulsory Land Purchase (CPO) should be avoided due to the lengthy process involved and acquiring land by agreement preferred.
- Statutory Bodies - This includes both public and private bodies such as the Environmental Agency (EA), the Internal Drainage Board (IDB), and those responsible for statutory services such as electricity, gas, water etc. At the detailed design stage, an inquiry will be sent out to all known utility companies to identify their services in the area.
- Drainage Consents - Potential issues with Culverts are that they become clogged with debris, which can cause problems with drainage and eventually lead to flooding. The design of any structures or structural extensions that affect watercourses must take this into account.

Areas of water course for proposed structures, or structural extensions, will match areas adjacent to existing structures to ensure the flow of the watercourse is unaffected. Correspondence and approval with the relevant drainage authorities for each structure will need to be obtained during the

design phase. Any required consents will be obtained before works commence and any conditions/constraints/mitigations that arise from these will need to be followed during the works.

3.6 Structures

LTN 1/20 section 10 states desirable minimum useable width between parapets of structures should be 4m but that more should be provided where possible. The recommended parapet height is 1.4m for any route used by cyclists. The levels of the underside of any new structures will need to be agreed with the relevant drainage authority (see 3.5 above) and the surface level of any new structures will depend on the span and depth of construction of the structural elements. The finished level of any structures may not be close to existing ground level and so approach embankments may be required to bring cycleway levels up the required level.

3.7 Geotechnical

Geotechnical investigation would need to be conducted at the locations of the new structures to determine the ground conditions and to enable a suitable foundation to be designed. Some Geotechnical information will also be required to support the cycleway and any embankment design elements

3.8 Ecological

An ecological walk over survey was undertaken in March 2023, which identified three potential ecological constraints: Water Voles, Great Crested Newts & Nesting Birds.

Water Voles

Any proposal to either extend the existing culverts or build new bridges adjacent to existing, would likely impact the banks of the three watercourses namely, New Cut linked to Cottenham Lode, Smithy Fen Engine Drain, and Catchwater Drain, and therefore water vole survey's will be required during the active season March to October inclusive. Water voles would need to be displaced before any works can be undertaken.

Great Crested Newts

There are waterbodies close to the road and existing cycleway which have high potential to support Great Crested Newts. If no ground works are required in green infrastructure and the hedges are to be retained, then the great crested newts are less likely to be a constraint, however the contractor would need to operate with care, and a precautionary method of working may be required.

Nesting Birds

Any Option that would involve removing the existing hedge line or vegetation would be subject to nesting season, which will have programme constraints on when the scheme can be constructed. New planting would also be required.

3.9 Utilities

Stats C2 information has shown multiple services running along the site in the carriageway, cycleway, and verges.

Underground utilities and overhead lines located in the areas of construction along Rampton road carriageway have been located. Prior to construction, trial hole investigations will need to be undertaken to confirm cover levels & invert levels of existing utilities. It is assumed in this Report that no utility diversions will be required, however this is to be confirmed during detailed design through the NRSWA diversionary process.

Utilities identified are listed below:

- South Staffs Water – supply main running in north cycleway. May affect work at Culvert B.
- Anglian Water – foul sewer.
- Virgin Media – buried services run over all structure's north cycleway.

Printed copies of this document are not controlled. The master document is controlled electronically. Document users are responsible for ensuring printed copies are valid prior to use.

- BT – buried services over Culvert D north cycleway.
- UKPN – overhead lines by Culvert C & D.

Utilities should be identified and clearly marked before works commence.

3.10 Site Constraints

There are existing farm accesses along the proposed improved cycle route. One is just east of Culvert B; an alternate route would need to be devised for farm access during construction. The other is at Culvert D; this farm access will be considered when deciding which Option is best for the location. Sufficient access will be provided for farm access during construction.

Furthermore, the pavement specification for the new facility would need to cater for heavy agricultural vehicles.

4.0 Alignment Options

The main objective of each Option was for a safe cycling facility to be available to the public connecting Rampton to Cottenham. Taking into consideration the constraints of the existing carriageway, LTN/120 recommends a 2.5m verge separation between cycle path & carriageway with the cycle path measuring a width of 3m. After inspection of the site, it was determined the proposed Options would be identical east of Culvert A and west of Culvert D. Between Culvert A & D is where Option 1 and 2 become available. Refer to drawing 5020600-MIN-HGN-DR-CH-0102 and 5020600-MIN-HGN-DR-CH-0106 in the appendix.

The key features which will not change in both Options are noted below.

- LTN/120 could not be achieved along the whole stretch of road between Rampton & Cottenham
- A parking layby located adjacent to 22 Church End will be suspended to facilitate a widened cycling facility.
- Existing signage is to be relocated where required.
- The existing path is to be broken out and returned to verge.
- Along the stretch of road four Culverts are to be constructed, these have been labelled A, B C & D.
- The stretch of hedges parallel to Rampton Road, along Giant's Hill Moat are protected – thus must be unaltered.
- Culvert A's design is identical in both Option 1 & 2.

Culvert A is a simple alteration, the existing balustrade is to be moved and relocated approx. 200-300mm away from the carriageway to increase the cycle path width.

The scheme starts at The Grn, located at the west end of the proposed site within Rampton Village. The 2m wide existing path to the North is to be widened to 3m. An existing bus shelter & tree are located along this narrow path, keeping both in-situ will cause a minor pinch point of approx. 2.0m (worst case). The existing 2m wide narrow path runs adjacent to several driveways; these are to be resurfaced to match the new cycle path.

Travelling East out of Rampton & onto Church End Road, the new 3m wide path can be maintained for approx. 70m, after which point the existing hedge line begins to encroach onto the existing path. The hedges are to be cut back 0.5m – 1.0m where possible, up to Culvert A to provide a 2.5m – 3.0m wide path. Between Church End Road & Culvert A, opposite Giants Hill Moat is where the protected existing hedge line is located; this will become a pinch point for the route, however a minimum path width of 2.0m is achievable. The exact highway boundary is unknown, and further investigations should be undertaken to establish the precise boundary.

To the far East end of the site after Culvert D (travelling East towards Cottenham), the existing carriageway width will be decreased to a minimum of 6m, increasing the width of the path. The decrease in carriageway width will take place east from Culvert D until the route enters Cottenham Village.

Printed copies of this document are not controlled. The master document is controlled electronically. Document users are responsible for ensuring printed copies are valid prior to use.

4.1 Option 1

4.1.1 Cycleway / Footway Design

Option 1 is for a 3.0m wide cycle path, with 2.5m wide verge providing separation to the carriageway, complying with LTN/120 guidance. After careful consideration this was unachievable along the whole stretch of carriageway due to various constraints, however between Culvert A and D is where LTN/120 guidance is attainable. Refer to drawing 5020600-MIN-HGN-DR-CH-0132 and 5020600-MIN-HGN-DR-CH-0104 in the appendix.

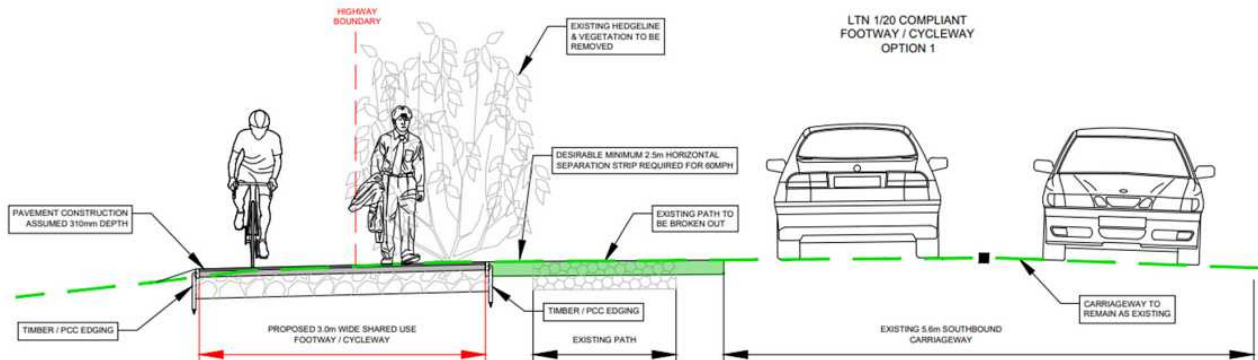

Figure 3: Option 1 - Typical Cross Section

During a site inspection a BT cabinet was noted 50 metres east of Culvert B; the cabinet can remain in place as the new verge will be built around. Measures should be put in place during construction, so no issues come from disturbing the cabinet and BT services.

As some of the proposed cycleway is not located within the highway boundary, approximately 1350m² of land purchase is required, however subject to detailed design, this figure may increase once 3d modelling and a drainage design has been undertaken. The existing landowners must be informed prior to construction. Existing accesses are located along Rampton Rd, which will need to be resurfaced to tie-n to the new cycling facility.

To facilitate and encourage the use of this Option, both the existing path & hedge line will be removed, however, to mitigate the loss of biodiversity, the new verge strip does provide sufficient width for some new low-level planting.

The existing hedge line sits extremely close to Rampton Rd, approximately 2.0m offset. During the removal of the hedge line & breaking out of the existing path, potential traffic management may be required for the duration of this construction. Once the hedge line is removed and footway removed, minimal traffic management will be required for constructing the new cycle path.

To facilitate the new cycle path, the existing Culverts A B, C & D are to be widened to provide a 4m wide path width, this is discussed further in section 4.1.2.

4.1.2 Structures Design

To achieve the criteria set by LTN 1/20 in Option 1, amendments and minor improvements will be required to existing structures between Culvert A and D.

Culvert A - After an initial site investigation, the only recommended proposal for Culvert A would be to remove the existing parapet, modify the top of the headwall and install a new cycleway parapet on top. This would provide up to approximately 200mm of additional width to the existing footway. The parapets would need to be 1.4m high to comply with LTN 1/20 guidance. Further works at this location is restricted due to the site being adjacent to a historical landmark (Giant's Hill). The solution for this location doesn't meet LTN 1/20

requirements and will be a pinch point for the cycleway providing a width of approximately 2.3m (minimum). This is considered acceptable as the cycleway to the west of this location will also be narrow due to site restrictions. Refer to drawing 5020600-MIN-SBR-DR-CB-1201 in the appendix.

Culvert B - An extension to the width of the existing bridge is proposed to achieve the width required by LTN 1/20 guidance. This would be in the form of new foundations and structure constructed immediately alongside the existing structure to provide the additional width and support a new cycleway parapet. It is not considered feasible to cantilever out from the edge of the existing bridge as the loads from the additional structural elements would negatively impact the foundations of the existing bridge. The existing wingwalls on the north face would be mostly removed to enable the construction of the proposed structural extension. The existing parapet beam will be taken down to the bottom of the existing footway surfacing. The proposed structural extension will be about the existing footway level providing a continuous width of useable cycleway constructed. The structural extension would need to be up to 3m wide to allow for a 3m cycleway with 0.5m buffer strips either side. This is a reduction in the width of buffer strip proposed at the carriageway edge elsewhere, as it is only for a short length and limits the additional structural elements required. The new structure will have a 500mm edge beam with a 1.4m high combined vehicular containment and cycleway height parapet installed. Refer to drawing 5020600-MIN-SBR-DR-CB-1202 in the appendix.

Culvert C - An extension is proposed to achieve the width required by LTN 1/20 guidance. This is achieved by partially demolishing and excavating the existing headwall, then adding a new section of concrete pipe and new headwalls to extend the width of the existing footpath. A 1.4m high parapet would be installed on top of the new headwall to comply with LTN 1/20. The extension plans to increase the width of the cycle way to 3m with a 0.5m buffer strip on either side as noted above at structure locations. The waterway area provided with the Culvert extension will match existing one, which should not cause any issues in relation to flooding. Refer to drawing 5020600-MIN-SBR-DR-CB-1203 in the appendix

4.2 Option 2

4.2.1 Cycleway / Footway Design

Option 2 is an offline route behind the existing hedge line. As Option 1, the cycling facility shall be 3.0m wide, however the separation strip will be increased to approximately 8.0 metres. This proposal remains compliant with LTN/120 guidance. Refer to drawing 5020600-MIN-HGN-DR-CH-0107 and 5020600-MIN-HGN-DR-CH-0108 in the appendix.

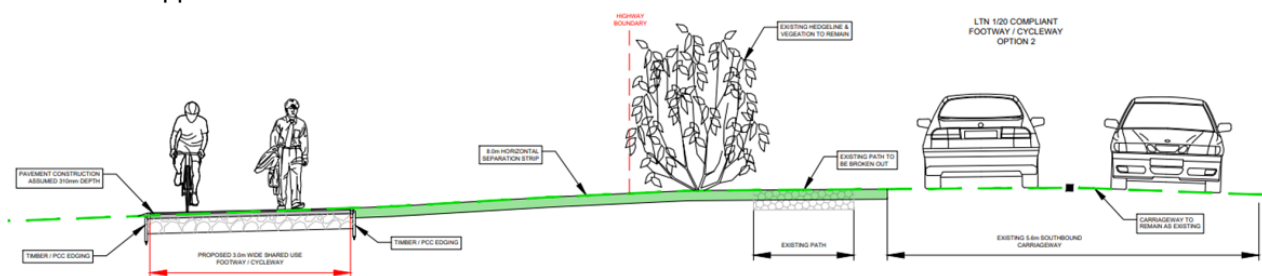

Figure 4: Option 2 - Typical Cross Section

As in Option 1, these widths are unachievable along the whole stretch of carriageway due to various constraints, however between Culvert A and D is where LTN/120 guidance is attainable.

Similarly with Option 1, the BT cabinet can remain in place.

Approximately 5050m² of land take is required, however subject to detailed design, this figure may change once 3d modelling and a drainage design has been undertaken. This area is over 3.5 times the amount when compared to Option 1; the increase in separation between the carriageway and new path is the cause of this. The increase in land take will no doubt incur a higher overall cost, which must be considered when deciding which Option is more viable.

As the existing hedge line is to remain in Option 2, the overall environmental damage will be minimal. Maintaining the hedge line also affects the potential need for traffic management, as mentioned in Option 1 traffic management will be required during the process of breaking out the existing the path. In Option 2 the new cycle path can be constructed behind the existing hedge line, providing a safe workspace for contractors. The only potential need of traffic management will be where the offline cycle route returns online.

Another positive is the new path & breaking out of the existing path can be completed simultaneously, whereas Option 1 the breaking out and replacement of verge must be completed prior to constructing the path.

The table below compares the benefits of either keeping the existing 2m wide path or removing & replacing with a verge or new hedge line.

Table 3: Advantages & Disadvantages of removing existing path.

Path to Remain	Existing Path Broken Out
Overall cost reduces.	Overall safety improved. No new conflict points would be created where the new path meets old.
Minimal traffic management.	Increased biodiversity.
Less labour required.	Users are encouraged to use the new facility, which is compliant with LTN 1/20.
Less waste.	Risk of disturbing any shallow utilities that are located within the existing pavement construction.
The existing path isn't LTN 1/20 compliant	

Note: traffic management is still required at the far East & West ends of the proposed site.

To facilitate the new cycle path, the existing Culverts B, C & D are to have new structures producing a 4m wide path width, this is discussed further in section 4.1.2. LTN/120 recommends a minimum horizontal radius of 4m which has been achieved.

4.2.2 Structures Design

Option 2 aims to provide a separate offline 3.0m wide cycleway and 4.0m wide cycleway over new structures. To achieve the criteria set by the LTN 1/20 additional structures and offline solutions between Culvert A and D have been proposed. As well as offline routes, Option 2 works also include some minor improvements to existing structures as described in section 4.1.2.

Culvert A - After the initial site investigation and site restrictions, Culvert A will undergo minor adjustments as described in 4.2.1 (Culvert A- Option 1).

Bridge B - This Option uses an offline solution with a separate cycleway bridge which spans 12m over the watercourse and is located 5m to the north of the existing highway bridge. The useable width between parapets provided by the proposed structure would be 4m with 1.4m high parapets. This Option meets the required width listed in the LTN 1/20 guidance. The two materials being considered for the main structural elements of the proposed footbridge are steel and FRP (fibre reinforced polymer). Both Options would be relatively straightforward to construct, but FRP being lighter would be easier to deliver to site and man handle during installation with less future maintenance required. However, FRP has a higher initial cost in comparison to the steel Option and at the span of 12m may not be as cost effective. The foundations of the new structure may need to be set on piled foundations depending on the existing ground conditions and the material selected for the construction. The soffit of the new cycleway as a minimum would need to be no lower than the soffit of the adjacent existing highway bridge. However, the drainage authority may insist on increased headroom over the watercourse when consulted. The proposed cycleway bridge will link to the proposed offline route to the west with a 1:20 ramp on an embankment up to the proposed cycleway level. It will tie into the East side close to the level of the adjacent existing hard standing which would be expected to only require a short tie in between levels.

Printed copies of this document are not controlled. The master document is controlled electronically. Document users are responsible for ensuring printed copies are valid prior to use.

Culvert C - This Option has two offline solutions, both providing a new structure spanning the watercourse to the north of the existing Culvert. The first Option would be to construct a new cycleway bridge as described above at Bridge B but with a much shorter span of only 7.5m. The new footbridge could be made using steel or FRP. FRP may be more cost effective at this span and would then only expect to be founded on standard spread foundations. This would be subject to the findings of ground investigations required prior to design. The second Option would see a new reinforced concrete box Culvert installed to the north the existing Culvert with new headwalls and wingwalls to each side. The box Culvert will provide a similar or greater waterway area to that of the existing Culvert, reducing the risk of flooding caused by the proposed structure. The size and levels of the new Culvert would need to be agreed with the drainage authority and flow calculations may be required to confirm the new Culvert would not cause any flooding issues. Both the Options will provide a 4m cycleway and have 1.4m parapets installed making them compliant with LTN 1/20 guidance.

Culvert D – This Option considers acquiring the existing piped Culvert which is to the north of the carriageway and assumed to be currently used for farmland access. The Culvert would then be improved to use as the start of the offline cycleway. It is however expected that this pipe may be deemed to be in poor condition, and so the Culvert could be demolished, and a new concrete pipe Culvert or small box Culvert installed in its place. As this is a small watercourse with an existing relatively small pipe carrying the access road there is no benefit in considering a cycleway bridge at this location The structure would provide a 4m wide cycleway with 1.4m parapets making it LTN 1/20 compliant. Another Option considered for this structure would be to retain the existing offline Culvert to the north of the carriageway and improve it for farmland access use only. This cycle route would then have to remain online and cross Culvert D along with the improvements identified in 4.1.2 before turning into the field and continuing as an offline route. This would continue to provide the landowner with access to their land and avoid the need for them to cross the proposed offline cycleway route.

4.3 Option Assessment

4.3.1 Cycleway / Footway Design

The advantages and disadvantages of the two highway alignments are considered below:

Option 1		
3.0m NMU facility with 2.5m separation strip to the edge of carriageway.	<p>Advantages</p> <ul style="list-style-type: none"> • New cycle path between Culvert A & D is LTN 1/20 compliant. • Less requirement for land purchase. • Minimum 20m radii can be provided for cyclists to avoid the need for dismounting. • Existing BT cabinet is unaffected. • Improvements to the existing path is permitted development, and therefore planning permission shouldn't be required. • Security of users • Non-linear construction phase 	<p>Disadvantages</p> <ul style="list-style-type: none"> • Existing hedge line will need to be removed, which could have a great impact on ecology. • Extending Culverts is expensive and labour intensive, • Construction work takes place alongside a live carriageway. • Existing VMS & Speed limit signs relocated. • Existing parking located adjacent to 22 Church End will be suspended. • Potential constraint with water voles, great crested newts and nesting birds.
Option 2		
3.0m offline NMU facility with 8.0m – 10.0m separation strip to the edge of carriageway.	<p>Advantages</p> <ul style="list-style-type: none"> • New cycle path between Culverts A & D is LTN 1/20 compliant. • Less traffic management will be required as most of the scheme can be constructed offline. • The existing hedge line can remain, reducing the impact on ecology. • There is a greater separation between the path and carriageway, improving overall safety. • The existing BT cabinet is unaffected. • New structures are simpler to design and build. 	<p>Disadvantages</p> <ul style="list-style-type: none"> • A significant area of land purchase is required. • Option 2 has a slightly longer route distance. • Much tighter path radii to adjoining structures compared to Option 1, however it is compliant with LTN 1/20. • The existing VMS and speed limit signs will need to be relocated. • Existing parking adjacent to 22 Church End will be suspended. • Planning permission could be required for offline route. • Security of users • Linear construction phase. • Potential constraint with water voles, and great crested newts.

Printed copies of this document are not controlled. The master document is controlled electronically. Document users are responsible for ensuring printed copies are valid prior to use.

4.3.2 Structures Design

The advantages and disadvantages of the two Options for each structure are considered below:

432678 – Rampton Bridge Culvert West (Culvert A)		
<p>Removing the existing parapet and installing parapet on top of existing headwall to increase the cycleway width.</p>	<p>Advantages</p> <ul style="list-style-type: none"> • The construction time would be less than having to build a new structure or an extension. • Lower cost in comparison to widening the structure or adding a new structure. • Project could be completed with minimal disturbance to traffic. • Lower environmental impact Works would be completed on highways land therefore no land would need to be purchased for the solution. • No drainage consent would be required for these works 	<p>Disadvantages</p> <ul style="list-style-type: none"> • Does not meet the requirements set out by the LTN 1/20 – the structure would provide approximately 2.3m (minimum) once the parapet is moved to the headwall. The cycleway will have a reduced width beyond this point in any event due to other constraints.
<p>Only one Option was considered for this structure, which is common to both Options 1 & 2. The Culvert is located directly next to Giants Hill, a scheduled monument. So, obtaining land to extend this structure or the adjacent existing footway is not possible.</p>		

432679 – Rampton Bridge (Culvert B)		
<p>Option 1 Proposed widening to the width required by LTN 1/20 with a structural extension beside the existing structure on its own foundations. The new structural extension would be up to 4m wide</p>	<p>Advantages</p> <ul style="list-style-type: none"> • The cycleway is compliant with the LTN 1/20 cycle infrastructure design. • Less land would need to be purchased outside of the highway land for this Option. 	<p>Disadvantages</p> <ul style="list-style-type: none"> • Traffic disturbance due to the road being adjacent to the construction works. • Complications with joining the new structure with the existing structure.

Printed copies of this document are not controlled. The master document is controlled electronically. Document users are responsible for ensuring printed copies are valid prior to use.

to allow for 3m cycleway with a 0.5m buffer strip either side.	<ul style="list-style-type: none"> • There would be limited requirements to construct approach embankments. 	<ul style="list-style-type: none"> • Restricts access to some areas for maintenance of the existing structure in future. • New Parapets may have to provide vehicle containment depending on the outcome of a risk assessment.
<p>Option 2 Separate new footbridge (4m wide) constructed to the north of the existing structure.</p>	<p>Advantages</p> <ul style="list-style-type: none"> • The cycleway being away from the carriageway provides more safety and comfort for the cyclists. • The cycleway is in compliance with the LTN 1/20 cycle infrastructure design. • Project could be completed with minimal disturbance to traffic as it will be constructed offline. • FRP maybe an Option for this bridge, which will have some buildability and maintenance benefits. • Riverbed shouldn't be disturbed during construction as the structure will have a clear span over the watercourse. 	<p>Disadvantages</p> <ul style="list-style-type: none"> • Slightly higher construction cost than Option 1. • Earthworks ramp required in the west approach. • Tight turns for the cyclists departing the bridge on the east end. • More land will need to be purchased outside the existing highways land.

436678 – Rampton Bridge Culvert East No 1 (Culvert C)

<p>Option 1 Demolish existing headwall, then adding a new concrete pipe and headwall to extend the footpath.</p>	<p>Advantages</p> <ul style="list-style-type: none"> • This Option offers lower construction cost. • The cycleway will meet the compliance of the LTN1/20 cycle infrastructure design. • Less land would need to be purchased outside of the highway land for this Option. 	<p>Disadvantages</p> <ul style="list-style-type: none"> • The extension of the pipe would disturb the riverbed and banks and require temp works to dam and over pump. • complications with joining a new section to existing.
---	--	--

		<ul style="list-style-type: none"> New Parapets may have to provide vehicle containment depending on the outcome of a risk assessment.
<p>Option 2 Adding a new footbridge away from the existing structure.</p>	<p>Advantages</p> <ul style="list-style-type: none"> Better environmentally as it has less impact to the riverbed and banks in comparison to the Culvert extension or new Culvert (Option 1 & 3). FRP maybe an Option for this bridge. Providing benefits such as easy buildability and lower future maintenance costs The cycleway will meet the compliance of the LTN 1/20 cycle infrastructure design. An offline Option would have less disruption to traffic during construction. Drainage authorities tend to prefer clear spans for new structures. 	<p>Disadvantages</p> <ul style="list-style-type: none"> The initial cost may be higher than the alternative Options. More land will need to be purchased outside the existing highways land. Foundation requirements may be more onerous than other Options.
<p>Option 3 Adding a new reinforced concrete box Culvert away from the existing footbridge.</p>	<p>Advantages</p> <ul style="list-style-type: none"> In comparison to Option 2 the Culvert will incorporate a simpler design with lower long term maintenance requirements. This cycleway will meet the compliance of the LTN 1/20 cycle infrastructure design. An offline Option would have less disruption to traffic during construction. 	<p>Disadvantages</p> <ul style="list-style-type: none"> Temporary diversion of the watercourse would be required during construction which adds cost and complications. Drainage authorities prefer clear spans for new structures so additional design work may be required to confirm the box selected would not cause issues with flooding More land will need to be purchased outside the existing highways land.

438678 – Rampton Bridge Culvert East No 2 (Culvert D)

Option 1	Advantages	Disadvantages
<p>Minor improvements – removing the existing parapet and installing parapet on top of existing headwall and widening the existing pathway by 0.5m.</p>	<ul style="list-style-type: none"> • The construction time would be less than having to build a new structure or an extension. • Lower cost in comparison to widening the structure or adding a new structure. • Lower environmental impact due to less works required. • Works would be completed on highways land therefore no land would need to be purchased for the solution. • No Drainage consent will be required 	<ul style="list-style-type: none"> • This cycleway will not meet the compliance of the LTN 1/20 – the structure would provide approximately 2.5m (minimum) once the parapet is moved (along with highways widening the existing footway). However, beyond this point there will be a reduced width and limited improvements to existing paths.
Option 2	Advantages	Disadvantages
<p>Acquiring the existing structure which seems to be used for farmland access and improving it to either use as an offline cycleway Option or to provide a better access to the farmland.</p>	<ul style="list-style-type: none"> • Amending and improving the existing pipe Culvert is a simple solution. • Could provide access for the farmer so the newly installed cycleway is protected from the farm vehicles crossing. • If the structure was used for the cycleway it would comply with LTN 1/20. • Safer for cyclists having an offline route away from traffic. 	<ul style="list-style-type: none"> • if used for cycleway – cyclists will have sharp turns to return to existing paths. • Riverbed and banks will be disturbed during construction and require temp works to dam and over pump. • Drainage consents will be required • More land will need to be purchased outside the existing highways land.

5.0 Cost Estimate

Cost estimates are provided below as an indication of the potential costs for the Options. The figures are rounded up for comparison. The costs shown exclude the following.

- Works to Statutory Undertakers services are not included
- Traffic Management or potential Restricted working hours are not included
- Treatment of contaminated land is not considered
- No cost for the detailed design is included estimate.
- Land acquisition and third-party agreements are not included for.
- Construction access constraints and specialist method of working not allowed for as unknown.
- Risk Allowance.

Table 4: Cost Estimate

Path Option	Construction Cost	Total Cost, including surveys, 46% Optimism Bias*
Option 1: 3.0m facility with 2.5m verge separation strip.	£930,027.88	£1,403,965
Option 2: 3.0m offline facility with 8.0m separation strip.	£1,060,995.02	£1,633,336

*46% Optimism bias is a requirement of all construction schemes at concept stage

6.0 Conclusion

The existing track connecting Rampton to Cottenham is unsuitable for safe use, especially for cyclists due to the current width of track, several pinch points and width of separation between the existing track and carriageway. For this reason, it is recommended improvements are considered along the whole stretch of the facility.

The 2 Options discussed are summarised in the table below.

Table 5: Option Criteria

Criteria	Option 1	Option 2
Length of route	1.46km	2.27km
Width of facility	2.0m-3.0m	2.0m-3.0m
Width of separation strip	2.5m	8.0m
Is traffic management required to construct the scheme?	Yes	Minimal
Is extensive vegetation clearance required	Yes	No
Potential Ecological Constraints?	Water Voles Great Crested Newts Nesting Birds	Water Voles Great Crested Newts (Possible) Nesting Birds (Possible)
Number of structures required?	3 x Culvert widening 1 x small new structure	1 x Culvert widening 3 x small structure
Is land purchase required?	Yes - 1349 m²	Yes – 5050 m ²
Cost	£1,403,956	£1,633,336

Considering the two Options discussed above, it is recommended that Option 2 be taken forward as the preferred Option. It achieves the objectives most comprehensively with the least perceived disadvantages.

Being able to construct the new cycle route with minimal traffic management & less overall environmental damage are highly advantageous from a design perspective, reducing overall cost and time. Option 2 utilises the efficiency of constructing 3 new structures to provide a safe route over the watercourses located along Rampton road; these structures are simpler to build and implement into the route compared to the widening of existing structures as per Option 1.

Appendix 1 - Rampton to Cottenham Cycle Counts

Table 6: Cycle Counts

Survey Date	Total Eastbound Cyclists	Total Westbound Cyclists
18/03/2023	14	14
19/03/2023	46	71
20/03/2023	15	21
21/03/2023	19	26
22/03/2023	16	23
23/03/2023	18	17
24/03/2023	28	19



Figure 5: Cycle count location

Appendix 2 – Highways Drawings



- NOTES:**
- DO NOT SCALE FROM THIS DRAWING.
 - REPORT ALL DISCREPANCIES TO THE DRAWING ORIGINATOR IMMEDIATELY
 - ALL MEASUREMENTS ARE IN METRES UNLESS STATED OTHERWISE
 - ALIGNMENT IS DRAWN ON OS BASE

- KEY:**
- EXISTING ASPHALT
 - EXISTING CARRIAGEWAY
 - PROPOSED 2m / 3m SHARE USE FACILITY
 - PROPOSED 2.5m VERGE
 - EXISTING HIGHWAY BOUNDARY
 - H
 PROPOSED ROAD SIGN
 - P
 EXISTING SIGN
 - PROPOSED LAND TAKE REQUIRED FOR WIDENED PATH: 1349.0m²

© CROWN COPYRIGHT AND DATABASE RIGHTS 2022 ORDNANCE SURVEY 100023205. YOU ARE PERMITTED TO USE THIS DATA SOLELY TO ENABLE YOU TO RESPOND TO, OR INTERACT WITH, THE ORGANISATION THAT PROVIDED YOU WITH THE DATA. YOU ARE NOT PERMITTED TO COPY, SUB-LICENCE, DISTRIBUTE OR SELL ANY OF THIS DATA TO THIRD PARTIES IN ANY FORM.

Rev	Date	Description	Drm	Chkd	App
P01	20/02/2023	FIRST ISSUE		HL	STE OJB
Revisions					

Client
Cambridgeshire Highways

 Vantage House,
 Vantage Park,
 Washingley Road,
 Huntingdon,
 PE29 6SR.

Drawing Originator
MILESTONE INFRASTRUCTURE
 A part of MGroup Services
 Woodlands Court,
 Burnham Road,
 Beaconsfield,
 Buckinghamshire,
 HP9 2SF
 This drawing is copyright of Milestone Infrastructure and shall not be reproduced without prior written permission

Drawing Status
 GW3: FEASIBILITY
 Title
PROPOSED SCHEME OPTION 1
 SHEET 1 OF 4

Project Name
RAMPTON ROAD CYCLEWAY

Sheet Size A1	Scale 1:2000	Drawn By HL	Checked by STE	Approved by OJB
		Drawn Date 15/11/2022	Checked Date 16/01/2023	Approved Date 17/02/2023

Drawing Number
5020600/MIN/HGN/DR/CH/0101

Status
S2

Rev
P01

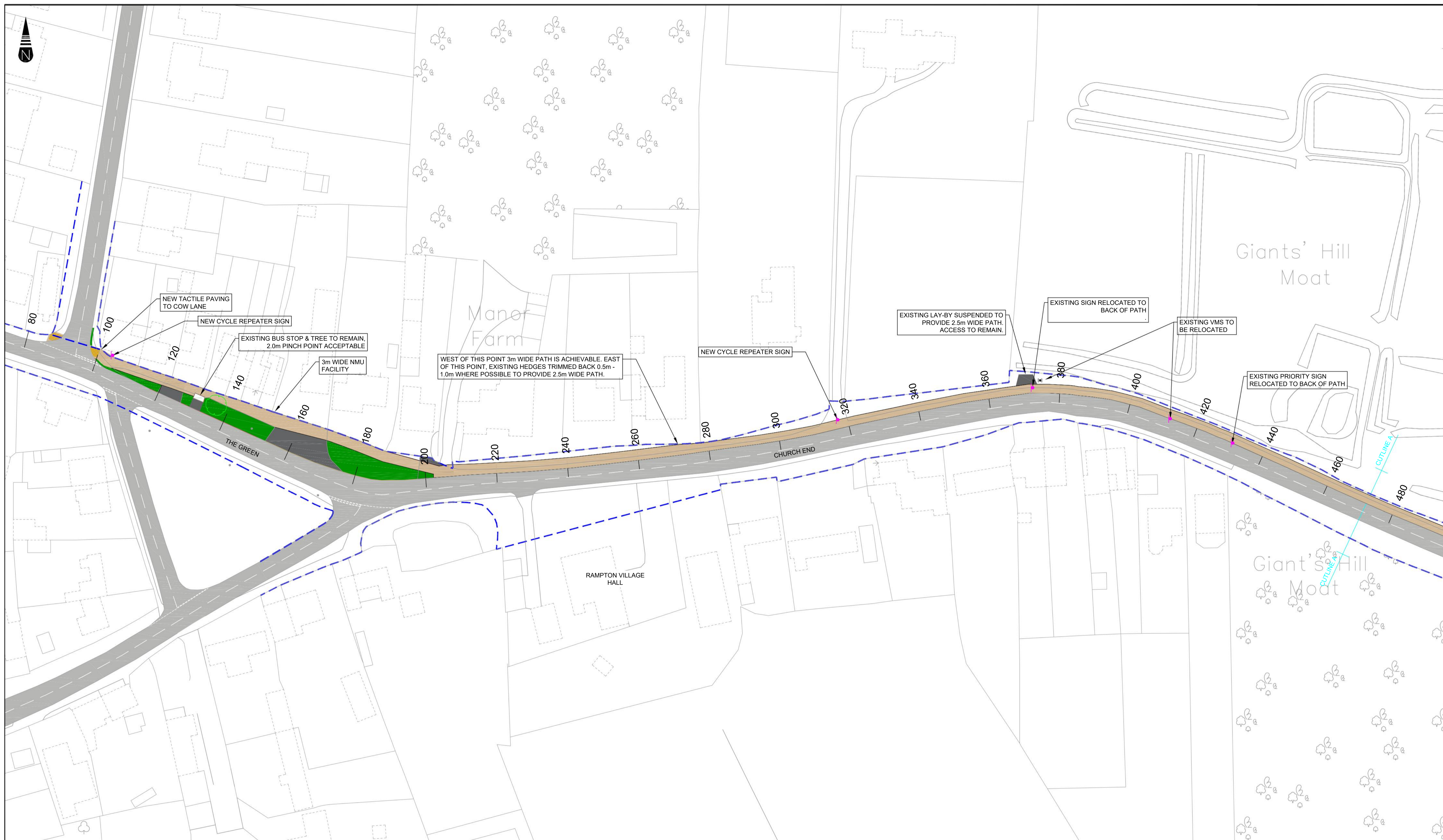

- NOTES:**
- DO NOT SCALE FROM THIS DRAWING.
 - REPORT ALL DISCREPANCIES TO THE DRAWING ORIGINATOR IMMEDIATELY
 - ALL MEASUREMENTS ARE IN METRES UNLESS STATED OTHERWISE
 - ALIGNMENT IS DRAWN ON OS BASE

KEY:

- EXISTING ASPHALT
- EXISTING CARRIAGEWAY
- PROPOSED 2m / 3m SHARE USE FACILITY
- PROPOSED 2.5m VERGE
- EXISTING HIGHWAY BOUNDARY
- PROPOSED ROAD SIGN
- EXISTING SIGN

Client	Cambridgeshire Highways			Drawing Originator			MILESTONE INFRASTRUCTURE		
Client	Cambridgeshire County Council			Drawing Originator			A part of MGroup Services		
Client	Vantage House, Vantage Park, Washingley Road, Huntingdon, PE29 6SR.			Drawing Originator			Woodlands Court, Burnham Road, Beaconsfield, Buckinghamshire, HP9 2SF		
Client	POT 20/02/2023 FIRST ISSUE			Drawing Originator			This drawing is copyright of Milestone Infrastructure and shall not be reproduced without prior written permission		
Client	Rev	Date	Description	Drm	Chkd	App			
Client	Revisions								

Client: **Cambridgeshire Highways**
 Cambridgeshire County Council

Drawing Originator: **MILESTONE INFRASTRUCTURE**
 A part of MGroup Services

Drawing Status: GW3: FEASIBILITY
 Title: PROPOSED SCHEME OPTION 1
 SHEET 2 OF 4

Project Name: RAMPTON ROAD CYCLEWAY

Sheet Size	Scale	Drawn By	Checked by	Approved by
A1	1:500	HL	STE	OJB
		Drawn Date	Checked Date	Approved Date
		15-11-22	16/01/2023	17/02/2023

Drawing Number	Status	Rev
50206000/MIN/HGN/DR/CH/0102	S2	P01

© CROWN COPYRIGHT AND DATABASE RIGHTS 2022 ORDNANCE SURVEY 100023205. YOU ARE PERMITTED TO USE THIS DATA SOLELY TO ENABLE YOU TO RESPOND TO, OR INTERACT WITH, THE ORGANISATION THAT PROVIDED YOU WITH THE DATA. YOU ARE NOT PERMITTED TO COPY, SUB-LICENCE, DISTRIBUTE OR SELL ANY OF THIS DATA TO THIRD PARTIES IN ANY FORM.

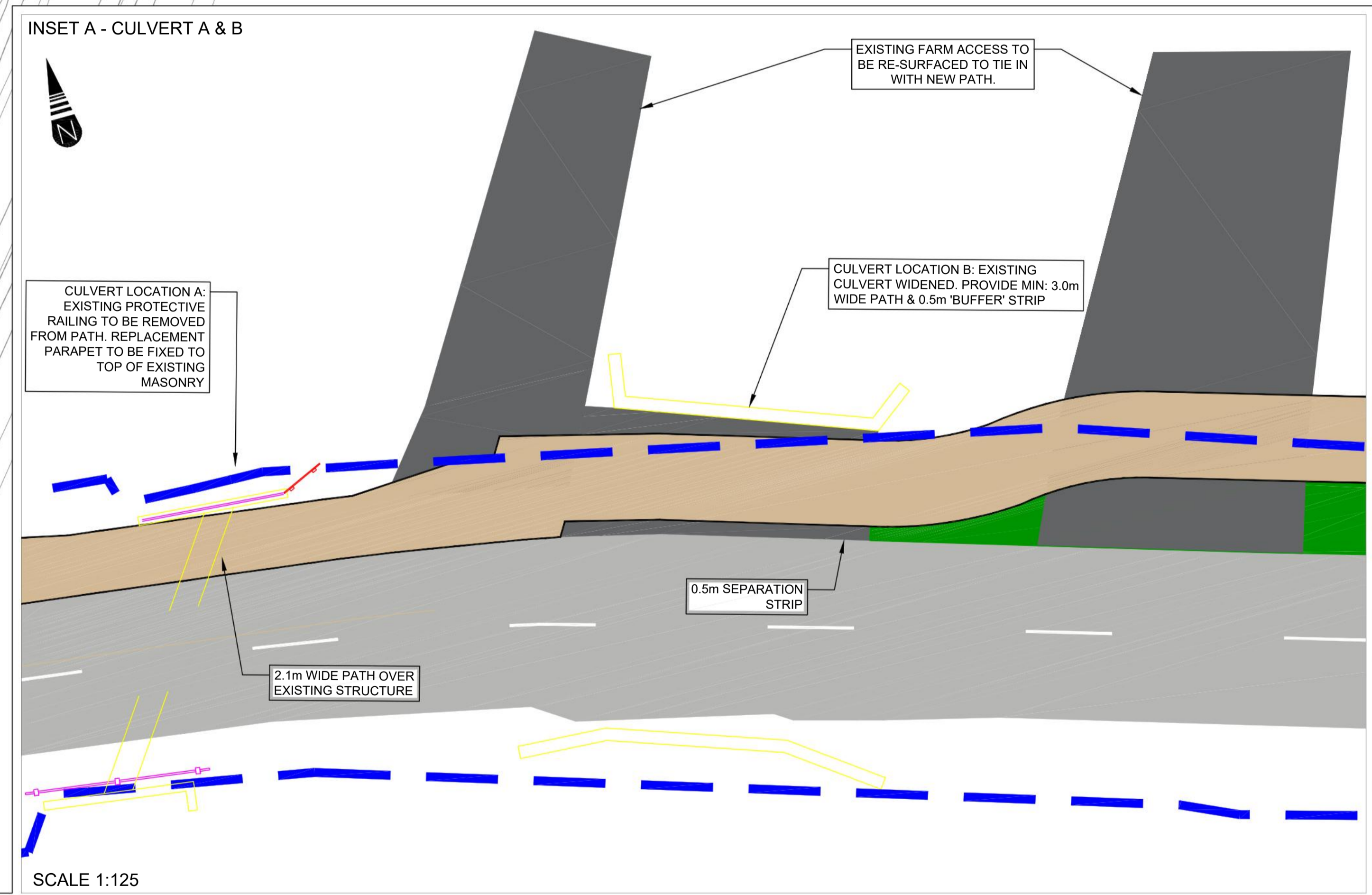
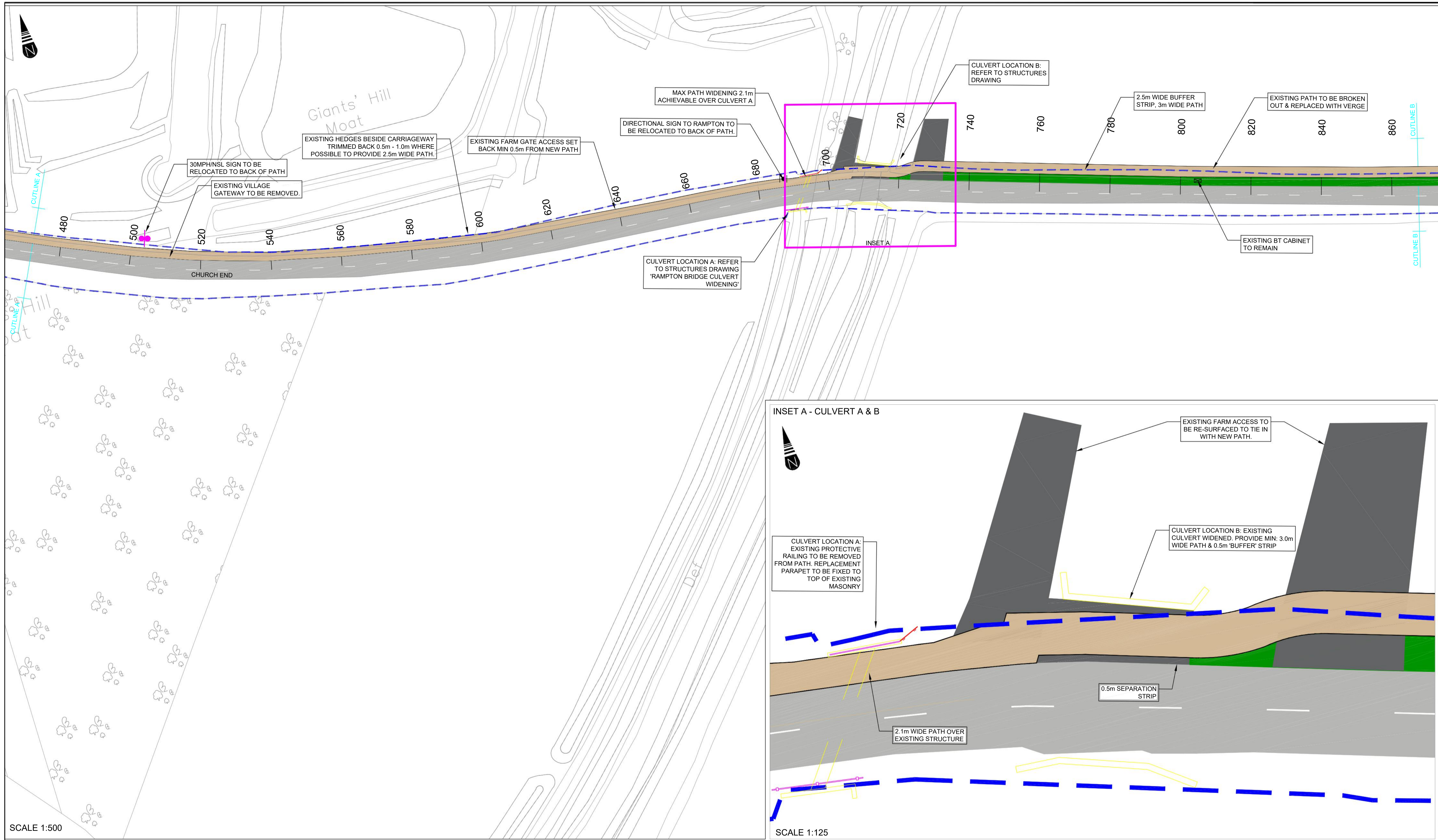

SCALE 1:500

NOTES:

- DO NOT SCALE FROM THIS DRAWING.
- REPORT ALL DISCREPANCIES TO THE DRAWING ORIGINATOR IMMEDIATELY
- ALL MEASUREMENTS ARE IN METRES UNLESS STATED OTHERWISE
- ALIGNMENT IS DRAWN ON OS BASE

KEY:

	EXISTING ASPHALT		EXISTING SIGN
	EXISTING CARRIAGEWAY		
	PROPOSED 2m / 3m SHARE USE FACILITY		
	PROPOSED 2.5m VERGE		
	EXISTING HIGHWAY BOUNDARY		
	PROPOSED ROAD SIGN		

© CROWN COPYRIGHT AND DATABASE RIGHTS 2022 ORDNANCE SURVEY 100023205. YOU ARE PERMITTED TO USE THIS DATA SOLELY TO ENABLE YOU TO RESPOND TO, OR INTERACT WITH, THE ORGANISATION THAT PROVIDED YOU WITH THE DATA. YOU ARE NOT PERMITTED TO COPY, SUB-LICENCE, DISTRIBUTE OR SELL ANY OF THIS DATA TO THIRD PARTIES IN ANY FORM.

Rev	Date	Description	Dm	Chkd	App
P01	20/02/2023	FIRST ISSUE		HL	STE OJB
Revisions					

Client
Cambridgeshire Highways
Cambridgeshire County Council

Drawing Originator
MILESTONE INFRASTRUCTURE
A part of MGroup Services

Vantage House,
Vantage Park,
Washingley Road,
Huntingdon,
PE29 6SR.

Woodlands Court,
Burnham Road,
Beaconsfield,
Buckinghamshire,
HP9 2SF

This drawing is copyright of Milestone Infrastructure and shall not be reproduced without prior written permission

Drawing Status
GW3: FEASIBILITY

Title
PROPOSED SCHEME OPTION 1 SHEET 3 OF 4

Project Name
RAMPTON ROAD CYCLEWAY

Sheet Size A1	Scale AS SHOWN	Drawn By HL	Checked by STE	Approved by OJB
		Drawn Date 15-11-22	Checked Date 16/01/2023	Approved Date 17/02/2023

Drawing Number: 5020600/MIN/HGN/DR/CH/0103 | Status: S2 | Rev: P01

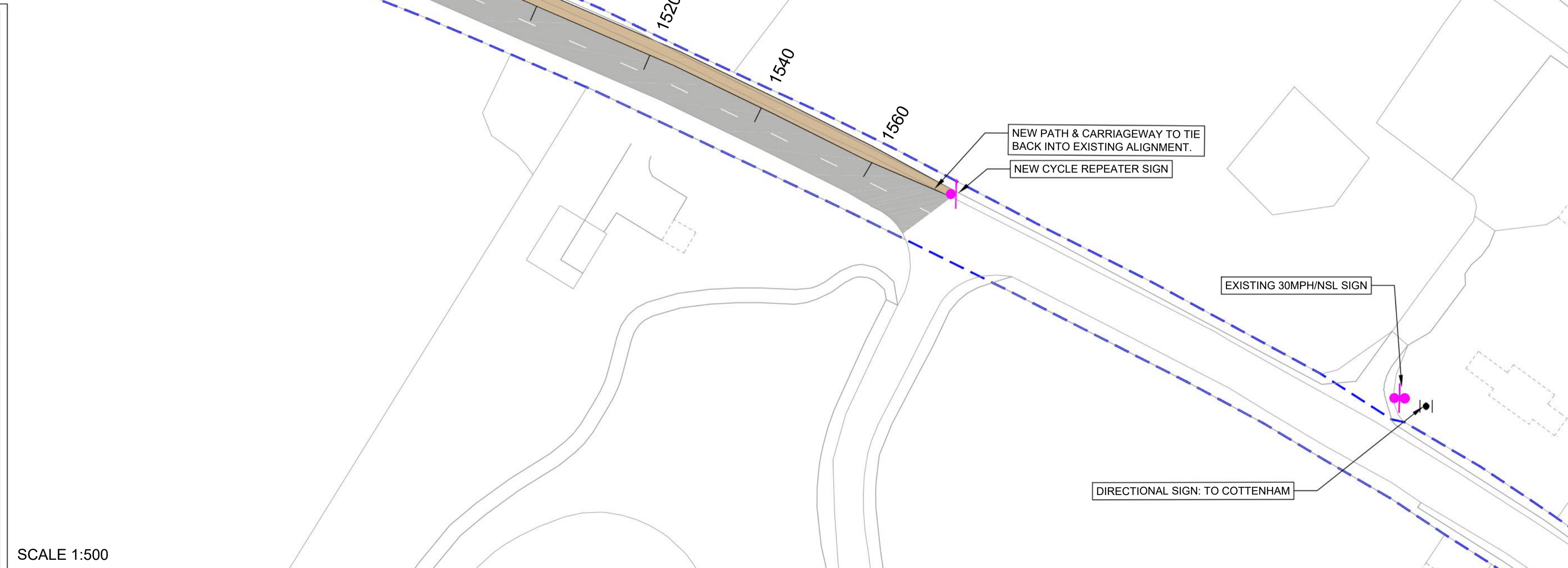
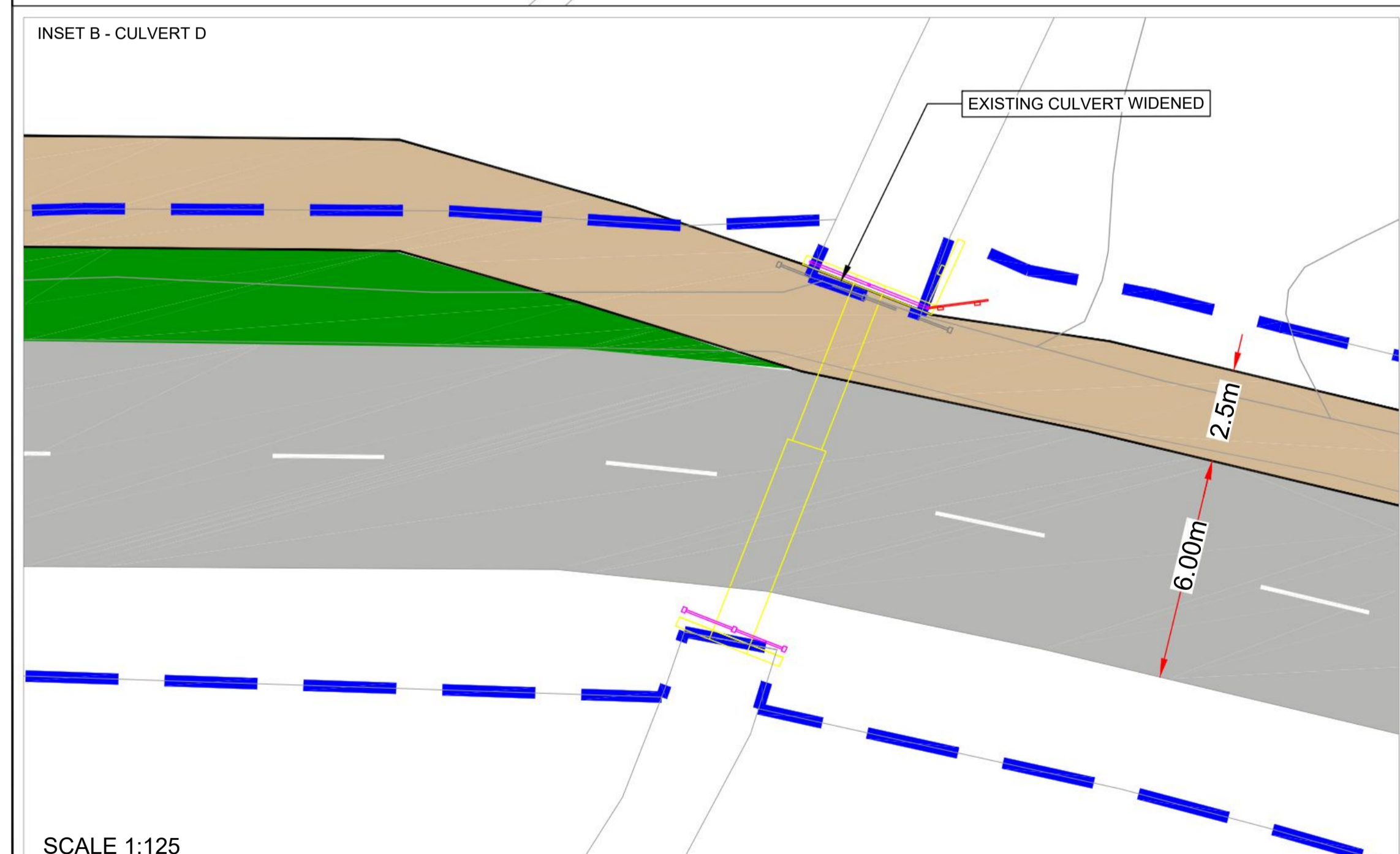
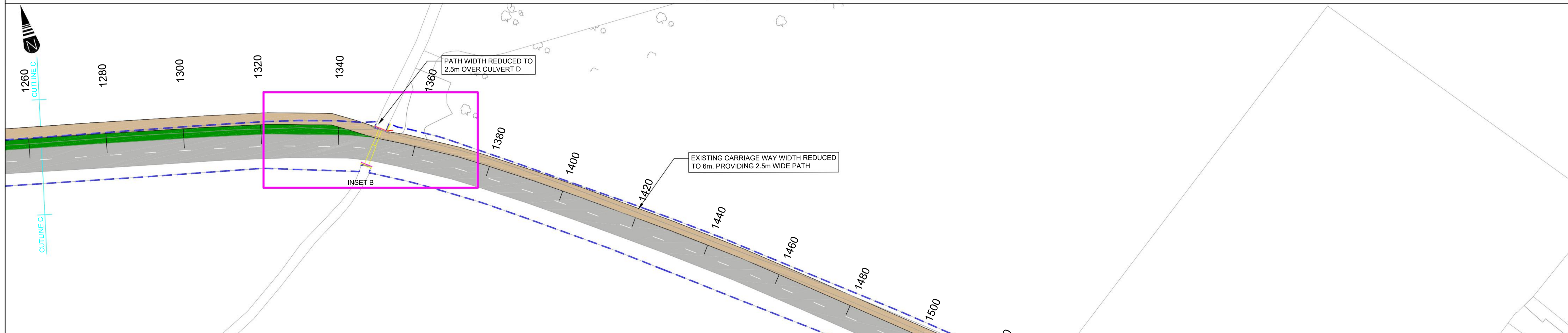
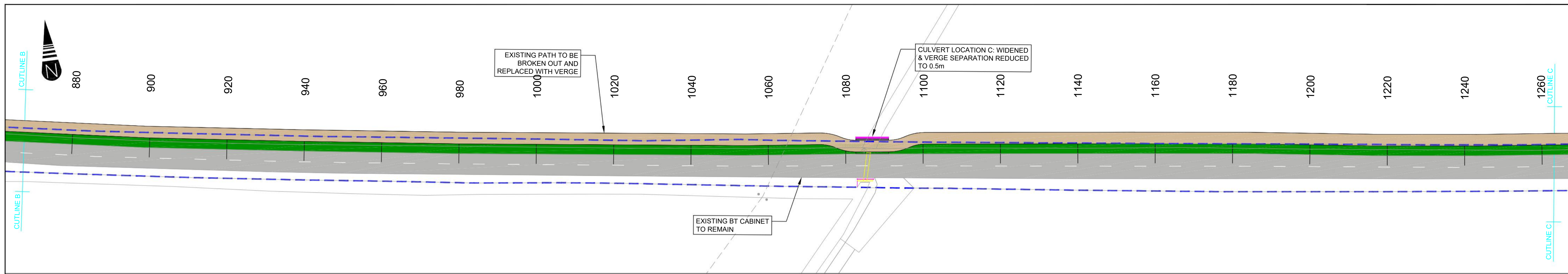

KEY:

- EXISTING ASPHALT
- EXISTING CARRIAGEWAY
- PROPOSED 2m / 3m SHARE USE FACILITY
- PROPOSED 2.5m VERGE
- EXISTING HIGHWAY BOUNDARY
- EXISTING SIGN
- PROPOSED ROAD SIGN

NOTES:

1. DO NOT SCALE FROM THIS DRAWING.
2. REPORT ALL DISCREPANCIES TO THE DRAWING ORIGINATOR IMMEDIATELY
3. ALL MEASUREMENTS ARE IN METRES UNLESS STATED OTHERWISE
4. ALIGNMENT IS DRAWN ON OS BASE

Rev	Date	Description	Drm	Chkd	App
P01	20/02/2023	FIRST ISSUE		HL	STE OJB
Revisions					

Client
Cambridgeshire Highways
Cambridgeshire County Council

Drawing Originator
MILESTONE INFRASTRUCTURE
A part of MGroup Services

Woodlands Court,
Burnham Road,
Beaconsfield,
Buckinghamshire,
HP9 2SF

This drawing is copyright of Milestone Infrastructure and shall not be reproduced without prior written permission

Drawing Status
GW3: FEASIBILITY

Title
PROPOSED SCHEME OPTION 1
SHEET 4 OF 4

Project Name
RAMPTON ROAD CYCLEWAY

Sheet Size A1	Scale AS SHOWN	Drawn By HL	Checked by STE	Approved by OJB
		Drawn Date 15-11-22	Checked Date 16/01/2023	Approved Date 17/02/2023

Drawing Number
5020600/MIN/HGN/DR/CH/0104

Status
S2

Rev
P01



- NOTES:**
- DO NOT SCALE FROM THIS DRAWING.
 - REPORT ALL DISCREPANCIES TO THE DRAWING ORIGINATOR IMMEDIATELY
 - ALL MEASUREMENTS ARE IN METRES UNLESS STATED OTHERWISE
 - ALIGNMENT IS DRAWN ON OS BASE

- KEY:**
- EXISTING ASPHALT
 - EXISTING CARRIAGEWAY
 - PROPOSED 2m / 3m SHARE USE FACILITY
 - PROPOSED 2.5m VERGE
 - EXISTING HIGHWAY BOUNDARY
 - PROPOSED ROAD SIGN
 - EXISTING SIGN
 - PROPOSED LAND TAKE REQUIRED FOR WIDENED PATH: 5050m²

© CROWN COPYRIGHT AND DATABASE RIGHTS 2022 ORDNANCE SURVEY 100023205. YOU ARE PERMITTED TO USE THIS DATA SOLELY TO ENABLE YOU TO RESPOND TO, OR INTERACT WITH, THE ORGANISATION THAT PROVIDED YOU WITH THE DATA. YOU ARE NOT PERMITTED TO COPY, SUB-LICENCE, DISTRIBUTE OR SELL ANY OF THIS DATA TO THIRD PARTIES IN ANY FORM.

Rev	Date	Description	Drm	Chkd	App
P01	20/02/2023	FIRST ISSUE		HL	STE OJB
Revisions					

Client
Cambridgeshire Highways
 Cambridgeshire County Council

Vantage House,
 Vantage Park,
 Washingley Road,
 Huntingdon,
 PE29 6SR.

Drawing Originator
MILESTONE INFRASTRUCTURE
 A part of MGroup Services

Woodlands Court,
 Burnham Road,
 Beaconsfield,
 Buckinghamshire,
 HP9 2SF

This drawing is copyright of Milestone Infrastructure and shall not be reproduced without prior written permission

Drawing Status
 GW3: FEASIBILITY

Title
**PROPOSED SCHEME
 OPTION 2
 SHEET 2 OF 4**

Project Name
 RAMPTON ROAD
 CYCLEWAY

Sheet Size A1	Scale 1:500	Drawn By HL	Checked by STE	Approved by OJB
		Drawn Date 15-11-22	Checked Date 16/01/2023	Approved Date 17/02/2023

Drawing Number: 5020600/MIN/HGN/DR/CH/0105 | Status: S2 | Rev: P01

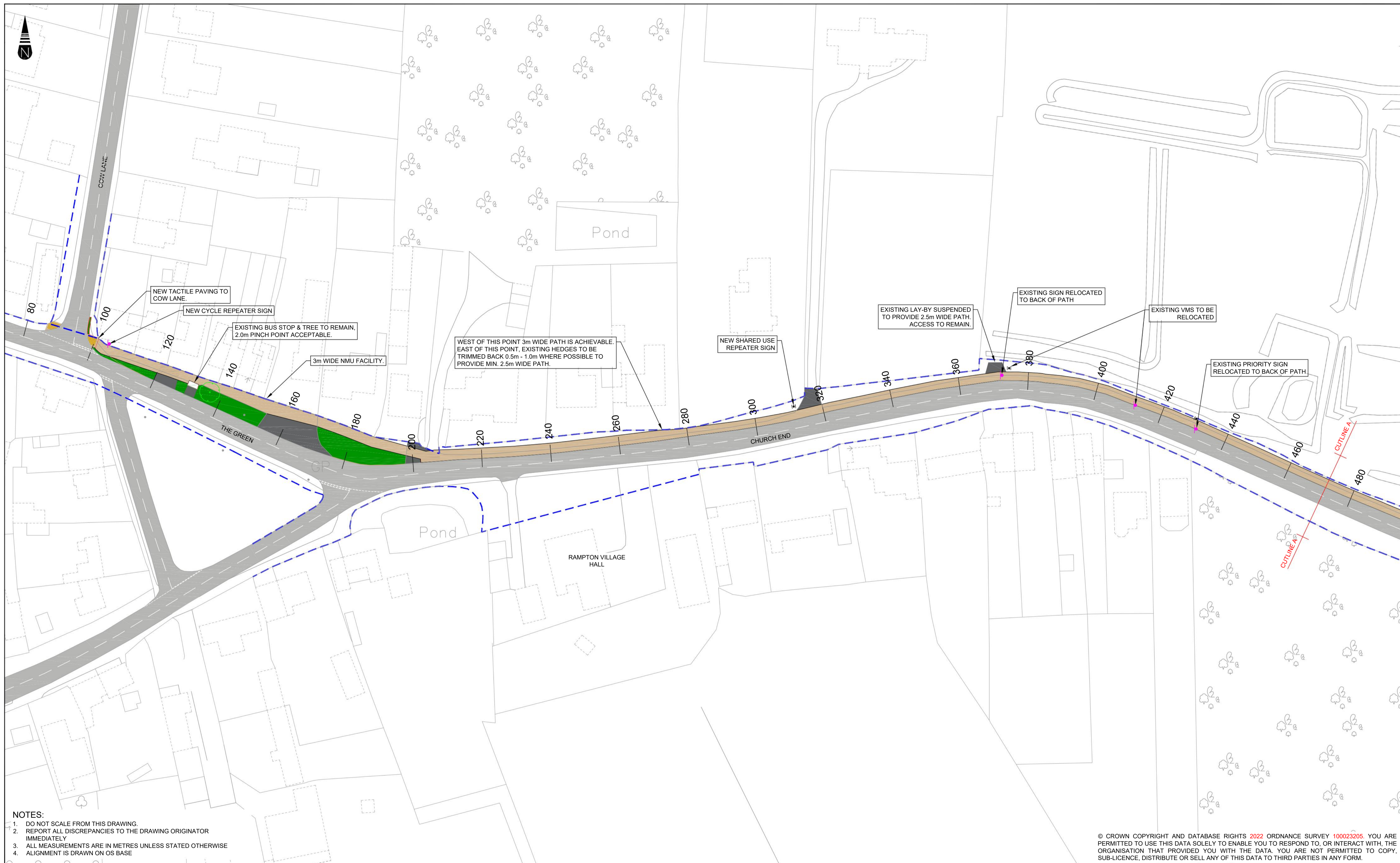

- NOTES:**
- DO NOT SCALE FROM THIS DRAWING.
 - REPORT ALL DISCREPANCIES TO THE DRAWING ORIGINATOR IMMEDIATELY
 - ALL MEASUREMENTS ARE IN METRES UNLESS STATED OTHERWISE
 - ALIGNMENT IS DRAWN ON OS BASE

KEY:

	EXISTING ASPHALT		EXISTING SIGN
	EXISTING CARRIAGEWAY		
	PROPOSED 2m / 3m SHARE USE FACILITY		
	PROPOSED 2.5m VERGE		
	EXISTING HIGHWAY BOUNDARY		
	PROPOSED ROAD SIGN		

PO1	20/02/2023	FIRST ISSUE	HL	STE	OJB
Rev	Date	Description	Drm	Chkd	App
Revisions					

Client
Cambridgeshire Highways

 Vantage House,
 Vantage Park,
 Washingley Road,
 Huntingdon,
 PE29 6SR.

Drawing Originator
MILESTONE INFRASTRUCTURE
 A part of MGroup Services
 Woodlands Court,
 Burnham Road,
 Beaconsfield,
 Buckinghamshire,
 HP9 2SF
 This drawing is copyright of Milestone Infrastructure and shall not be reproduced without prior written permission

Drawing Status
 GW3: FEASIBILITY
 Title
PROPOSED SCHEME OPTION 2 SHEET 2 OF 4

Project Name
RAMPTON ROAD CYCLEWAY

Sheet Size A1	Scale 1:500	Drawn By HL	Checked by STE	Approved by OJB
		Drawn Date 15-11-22	Checked Date 16/01/2023	Approved Date 17/02/2023

Drawing Number
5020600/MIN/HGN/DR/CH/0106

Status S2	Rev P01
--------------	------------

© CROWN COPYRIGHT AND DATABASE RIGHTS 2022 ORDNANCE SURVEY 100023205. YOU ARE PERMITTED TO USE THIS DATA SOLELY TO ENABLE YOU TO RESPOND TO, OR INTERACT WITH, THE ORGANISATION THAT PROVIDED YOU WITH THE DATA. YOU ARE NOT PERMITTED TO COPY, SUB-LICENCE, DISTRIBUTE OR SELL ANY OF THIS DATA TO THIRD PARTIES IN ANY FORM.

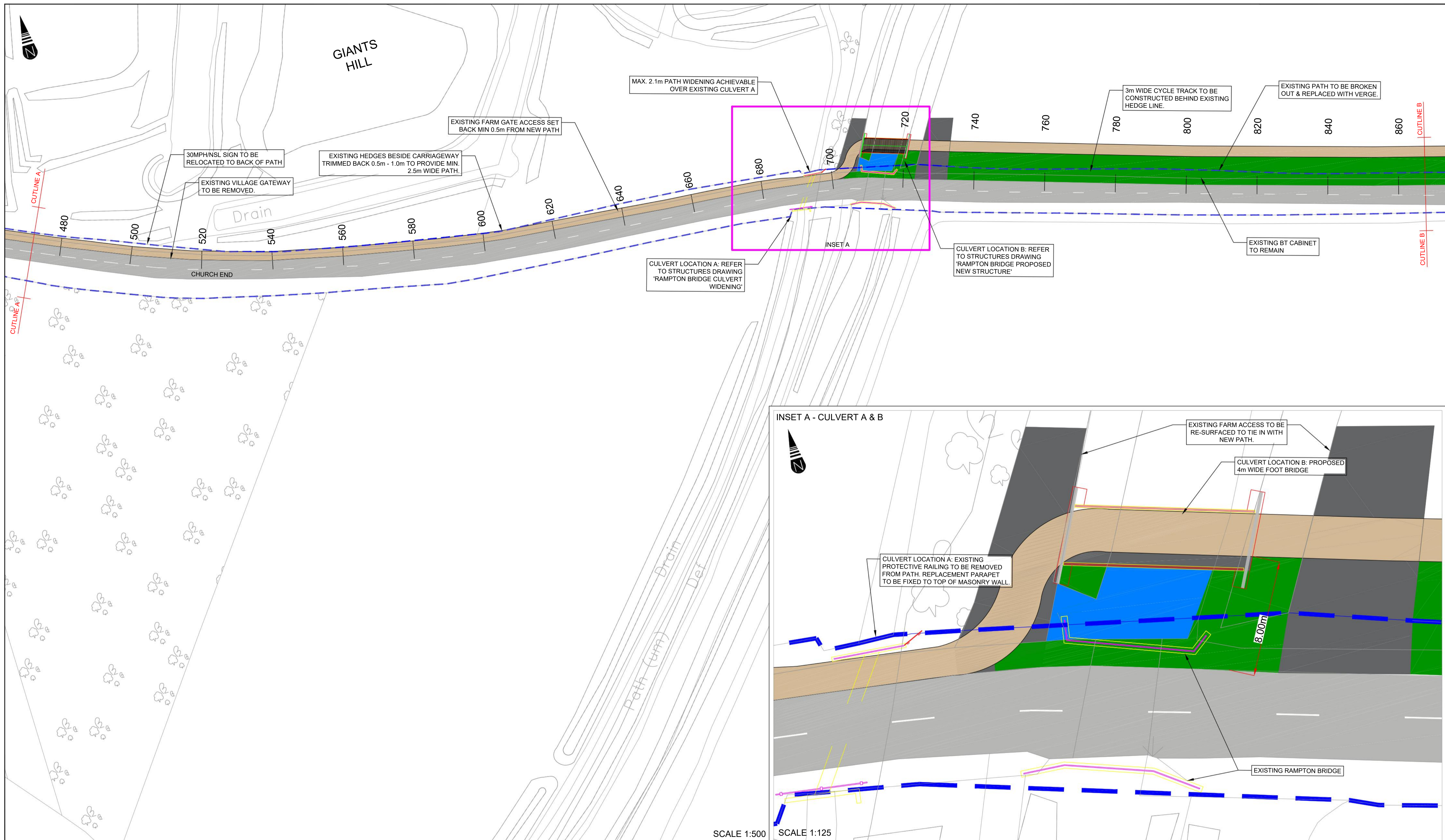

- NOTES:**
- DO NOT SCALE FROM THIS DRAWING.
 - REPORT ALL DISCREPANCIES TO THE DRAWING ORIGINATOR IMMEDIATELY
 - ALL MEASUREMENTS ARE IN METRES UNLESS STATED OTHERWISE
 - ALIGNMENT IS DRAWN ON OS BASE

KEY:

	EXISTING ASPHALT		EXISTING SIGN
	EXISTING CARRIAGEWAY		
	PROPOSED 2m / 3m SHARE USE FACILITY		
	PROPOSED 2.5m VERGE		
	EXISTING HIGHWAY BOUNDARY		
	PROPOSED ROAD SIGN		

© CROWN COPYRIGHT AND DATABASE RIGHTS 2022 ORDNANCE SURVEY 100023205. YOU ARE PERMITTED TO USE THIS DATA SOLELY TO ENABLE YOU TO RESPOND TO, OR INTERACT WITH, THE ORGANISATION THAT PROVIDED YOU WITH THE DATA. YOU ARE NOT PERMITTED TO COPY, SUB-LICENCE, DISTRIBUTE OR SELL ANY OF THIS DATA TO THIRD PARTIES IN ANY FORM.

Rev	Date	Description	Dm	Chkd	App
P01	20/02/2023	FIRST ISSUE		HL	STE OJB
Revisions					

Client
Cambridgeshire Highways
 Cambridgeshire County Council

Vantage House,
 Vantage Park,
 Washingley Road,
 Huntingdon,
 PE29 6SR.

Drawing Originator
MILESTONE INFRASTRUCTURE
 A part of MGroup Services

Woodlands Court,
 Burnham Road,
 Beaconsfield,
 Buckinghamshire,
 HP9 2SF

This drawing is copyright of Milestone Infrastructure and shall not be reproduced without prior written permission

Drawing Status
 GW3: FEASIBILITY

Title
PROPOSED SCHEME OPTION 2 SHEET 3 OF 4

Project Name
 RAMPTON ROAD CYCLEWAY

Sheet Size A1	Scale AS SHOWN	Drawn By HL	Checked by STE	Approved by OJB
		Drawn Date 15-11-22	Checked Date 16/01/2023	Approved Date 17/02/2023

Drawing Number: 5020600/MIN/HGN/DR/CH/0107 | Status: S2 | Rev: P01

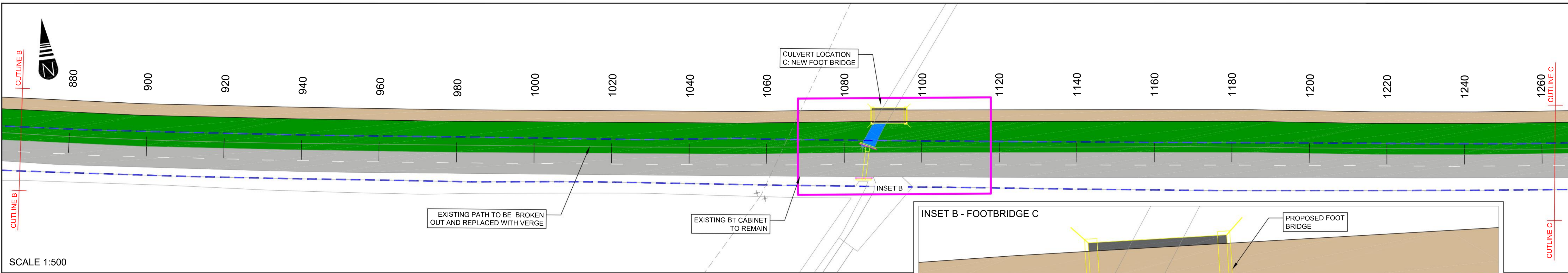

SCALE 1:500

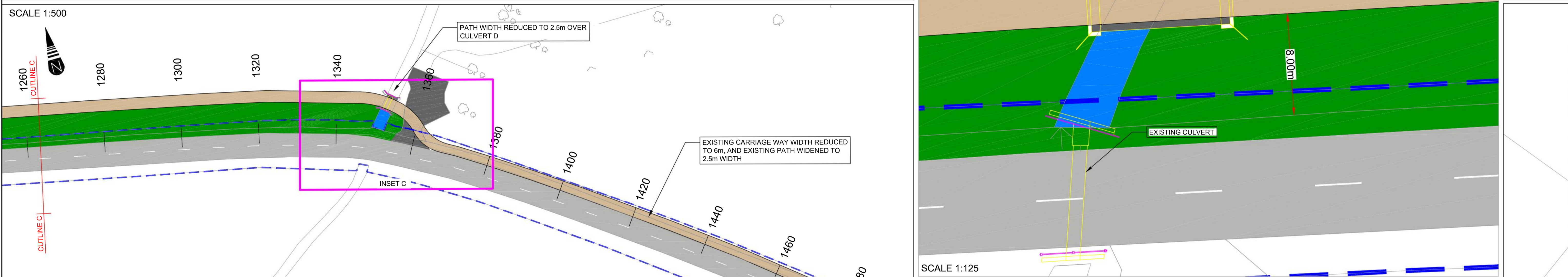

SCALE 1:500

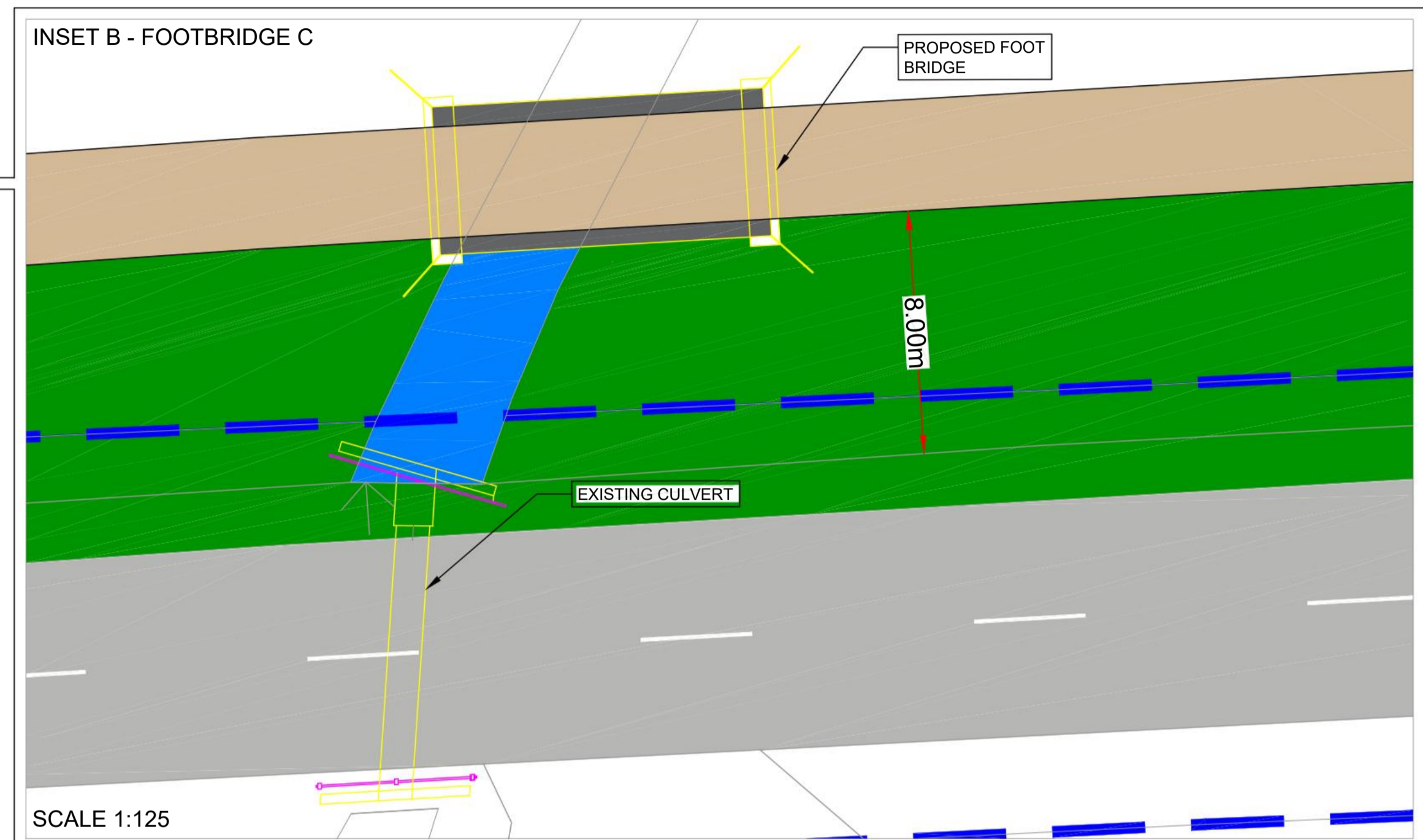

SCALE 1:125

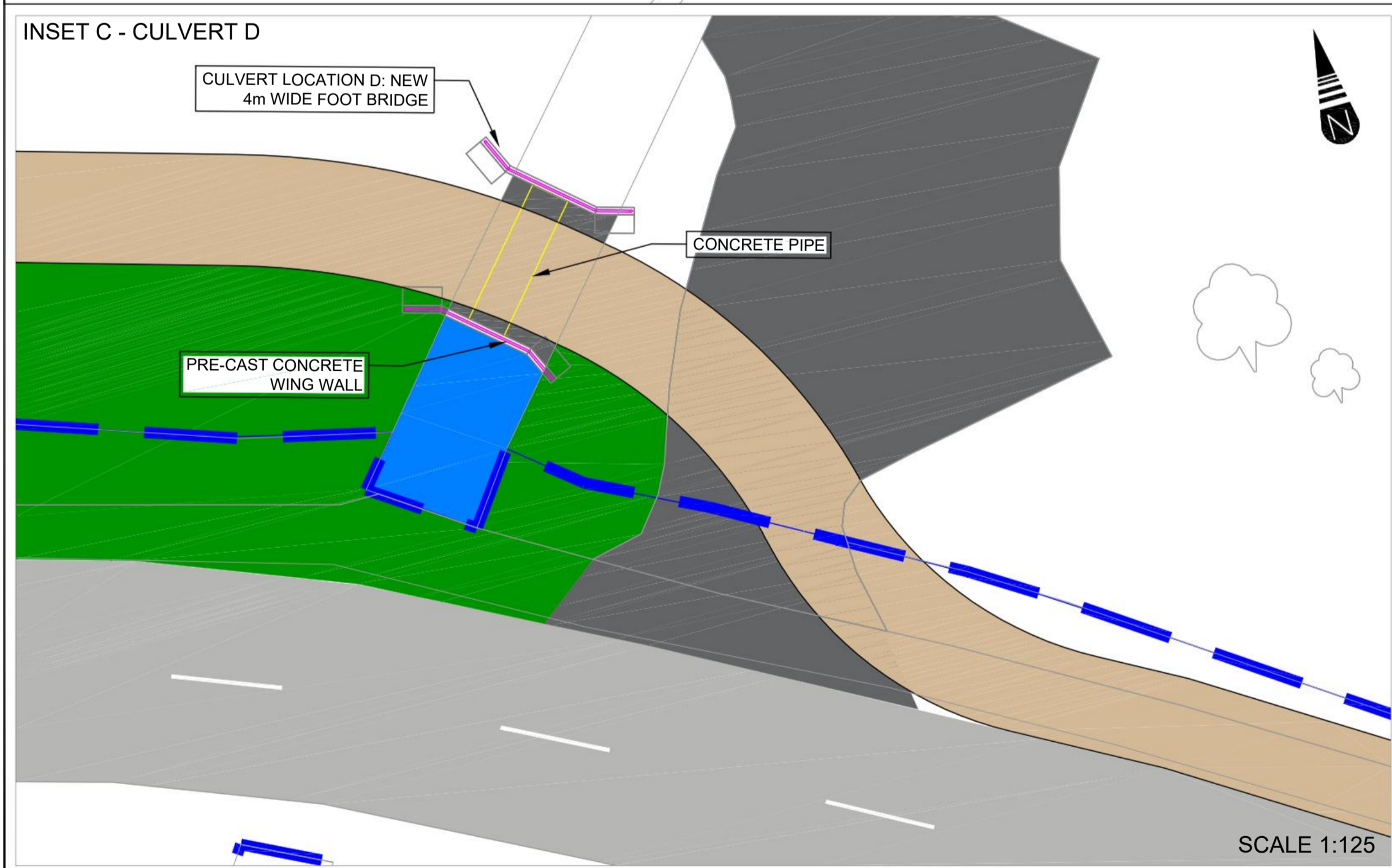

SCALE 1:125

- NOTES:**
- DO NOT SCALE FROM THIS DRAWING.
 - REPORT ALL DISCREPANCIES TO THE DRAWING ORIGINATOR IMMEDIATELY
 - ALL MEASUREMENTS ARE IN METRES UNLESS STATED OTHERWISE
 - ALIGNMENT IS DRAWN ON OS BASE

KEY:

	EXISTING ASPHALT		EXISTING SIGN
	EXISTING CARRIAGEWAY		
	PROPOSED 2m / 3m SHARE USE FACILITY		
	PROPOSED 2.5m VERGE		
	EXISTING HIGHWAY BOUNDARY		
	PROPOSED ROAD SIGN		

Client	Cambridgeshire Highways	Drawing Originator	MILESTONE INFRASTRUCTURE		
Client	Cambridgeshire County Council	Drawing Originator	A part of MGroup Services		
Rev	Date	Description	Drm	Chkd	App
P01	20/02/2023	FIRST ISSUE	HL	STE	OJB
Revisions					

Client
Cambridgeshire Highways
Cambridgeshire County Council

Vantage House,
Vantage Park,
Washingley Road,
Huntingdon,
PE29 6SR.

Drawing Originator
MILESTONE INFRASTRUCTURE
A part of MGroup Services

Woodlands Court,
Burnham Road,
Beaconsfield,
Buckinghamshire,
HP9 2SF

This drawing is copyright of Milestone Infrastructure and shall not be reproduced without prior written permission

Drawing Status
GW3: FEASIBILITY

Title
**PROPOSED SCHEME
OPTION 2
SHEET 4 OF 4**

Project Name
RAMPTON ROAD
CYCLEWAY

Sheet Size	Scale	Drawn By	Checked by	Approved by
A1	AS SHOWN	HL	STE	OJB
		Drawn Date	Checked Date	Approved Date
		15-11-22	16/01/2023	17/02/2023

Drawing Number: 5020600/MIN/HGN/DR/CH/0108

Status: S2

Rev: P01

Appendix 3 – Structures Drawings

- NOTES:
- DO NOT SCALE FROM THIS DRAWING.
 - SITE VERIFY ALL DIMENSIONS PRIOR TO CONSTRUCTION.
 - REPORT ALL DISCREPANCIES TO THE DRAWING ORIGINATOR IMMEDIATELY.
 - THIS DRAWING IS TO BE READ IN CONJUNCTION WITH ALL RELEVANT DOCUMENTS AND DRAWINGS.

Residual Risk Assessment
 Wherever possible, risk is designed-out of this proposal during the design process. Where this is not possible the risk is indicated by this symbol.



SIGNIFICANT CDM HEALTH & SAFETY RISKS

- WORKING NEAR WATERCOURSE.
- WORKING NEAR LIVE TRAFFIC.

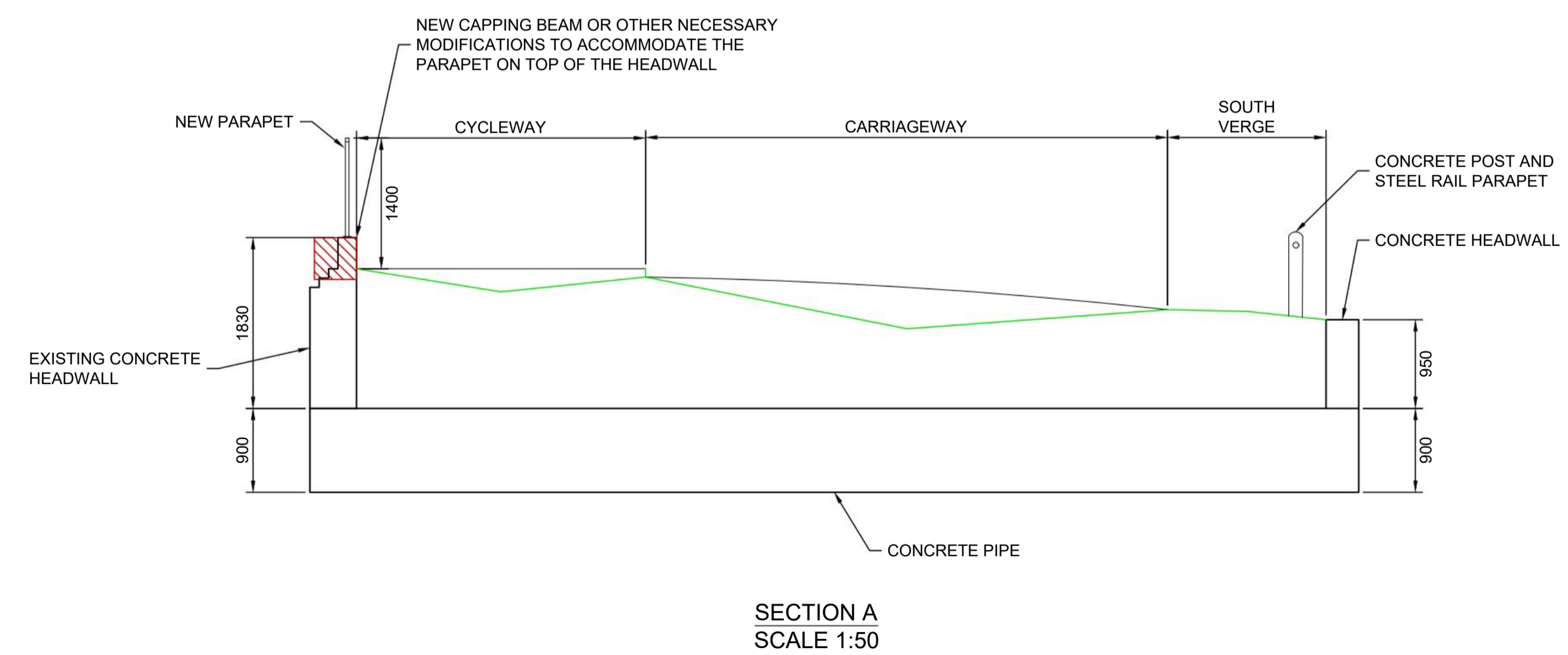
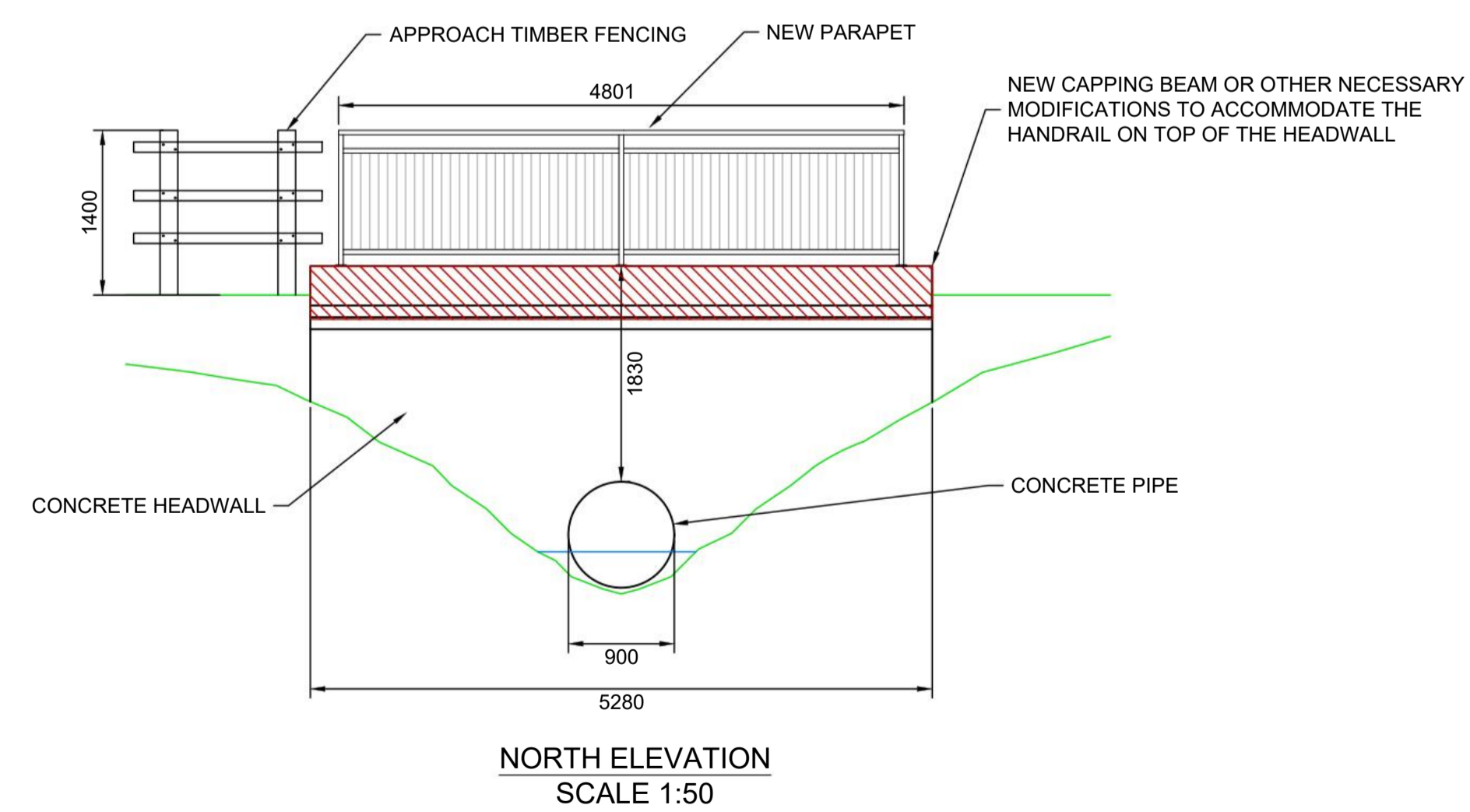
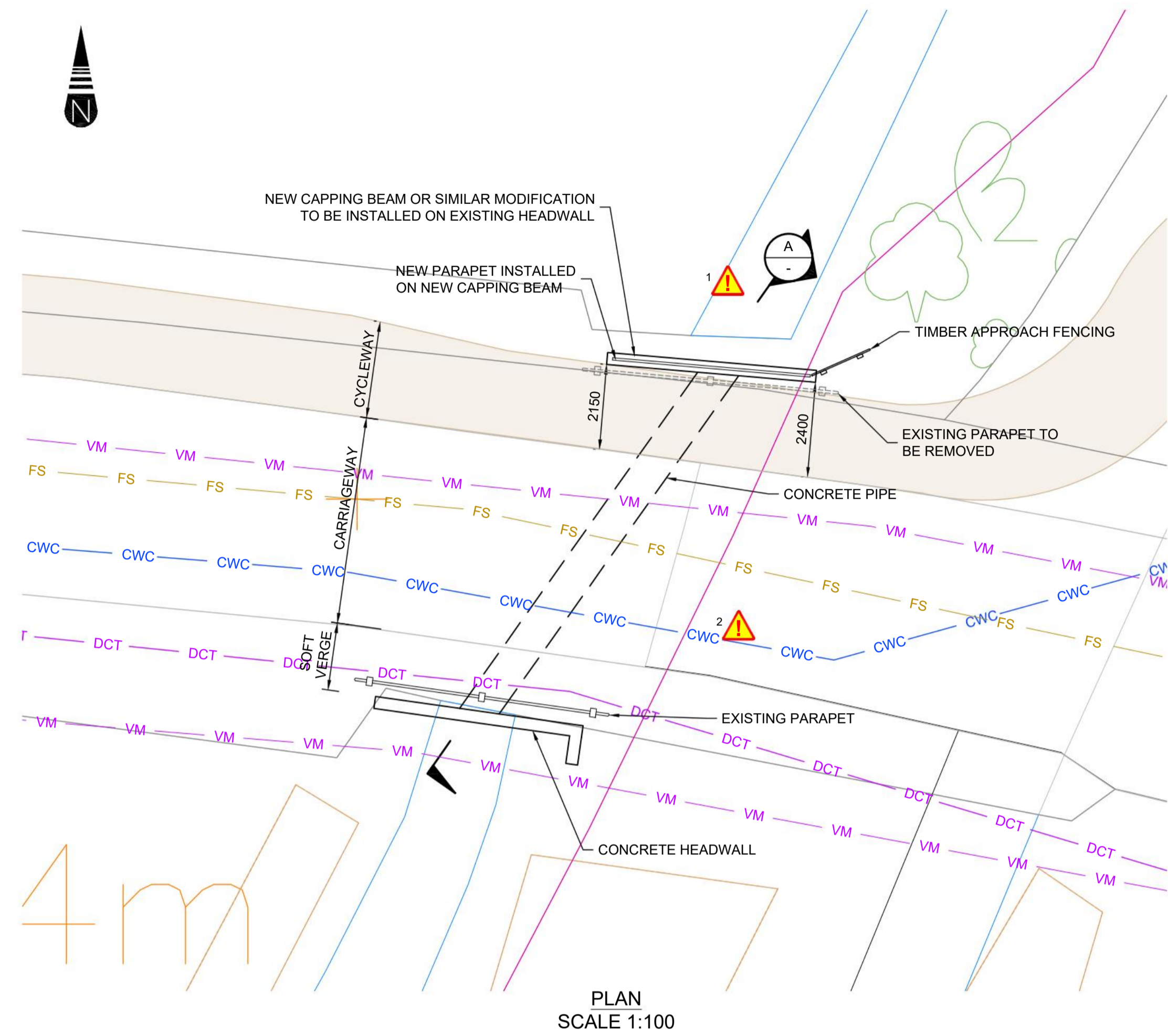

Rev	Date	Description	Drn	Chkd	App
P01	01/02/23	First Issue		CS	AC

Client
Cambridgeshire Highways
 Cambridgeshire County Council
 Vantage House, Vantage Park, Washingley Road, Huntingdon, PE29 6SR.

Drawing Originator
MILESTONE INFRASTRUCTURE
 A part of MGroup Services
 Woodlands Court, Burnham Road, Beaconsfield, Buckinghamshire, HP9 2SF. This drawing is copyright of Milestone Infrastructure and shall not be reproduced without prior written permission.

FOR INFORMATION
 Project Name
RAMPTON TO COTTENHAM CYCLEWAY
 Title
CULVERT A PROPOSED WIDENING

Sheet Size	Scale	Drawn by	Checked by	Approved by
A1	AS SHOWN	CS	AC	AC
		Drawn Date	Checked Date	Approved Date
		19-10-22	31-01-23	31-01-23

Drawing Number	Status	Rev
5020600-MIN-SBR-DR-CB-1201	S2	P01

© Crown copyright and database rights XXXX Ordnance Survey 100023205. You are permitted to use this data solely to enable you to respond to, or interact with, the organisation that provided you with the data. You are not permitted to copy, sub-licence, distribute or sell any of this data to third parties in any form.

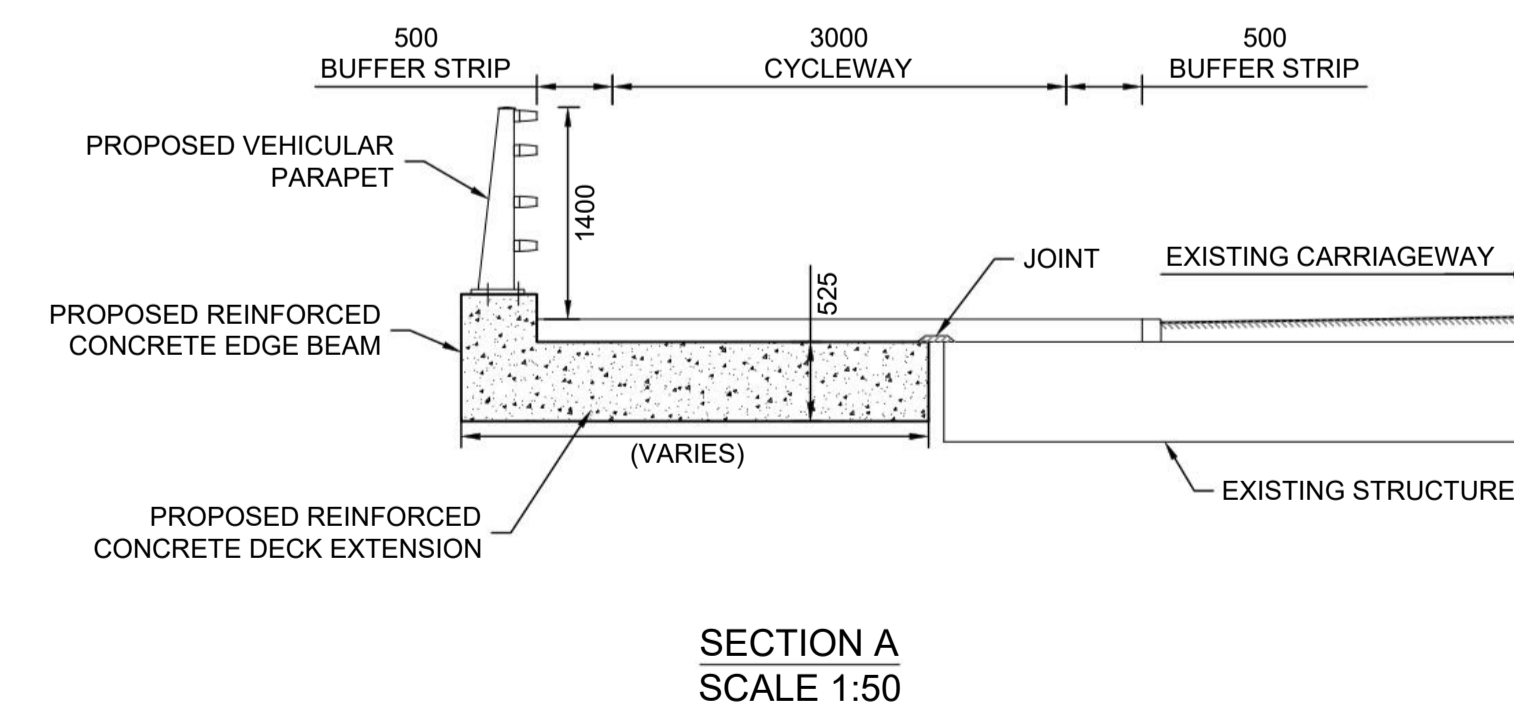
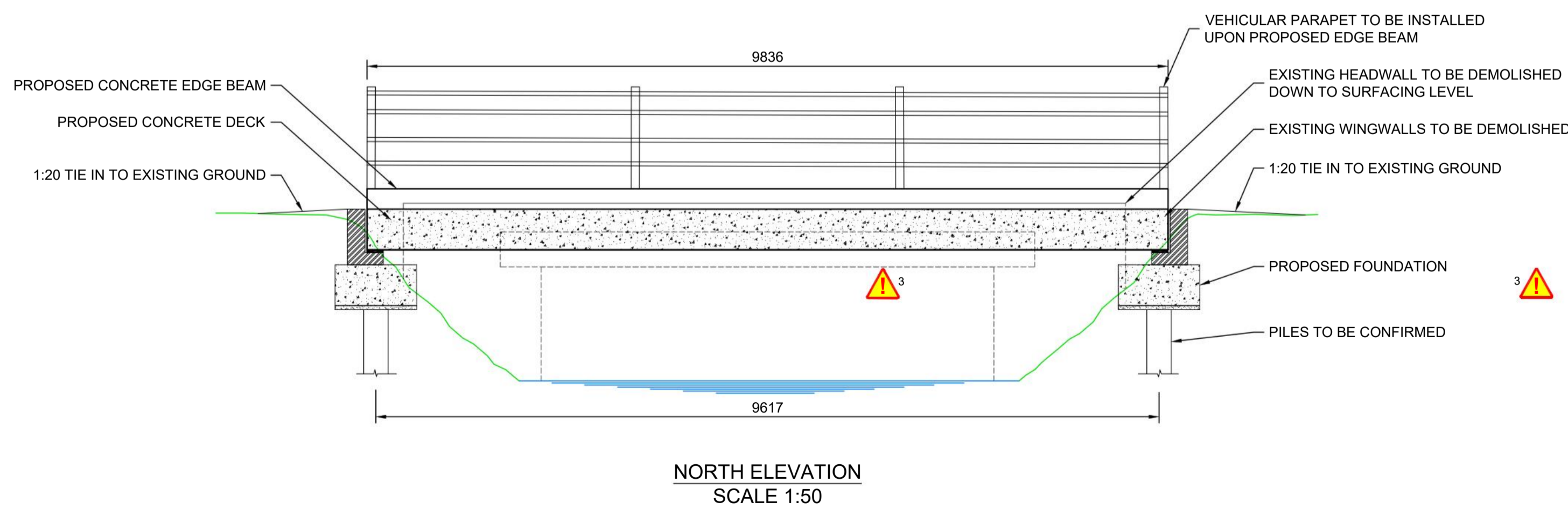
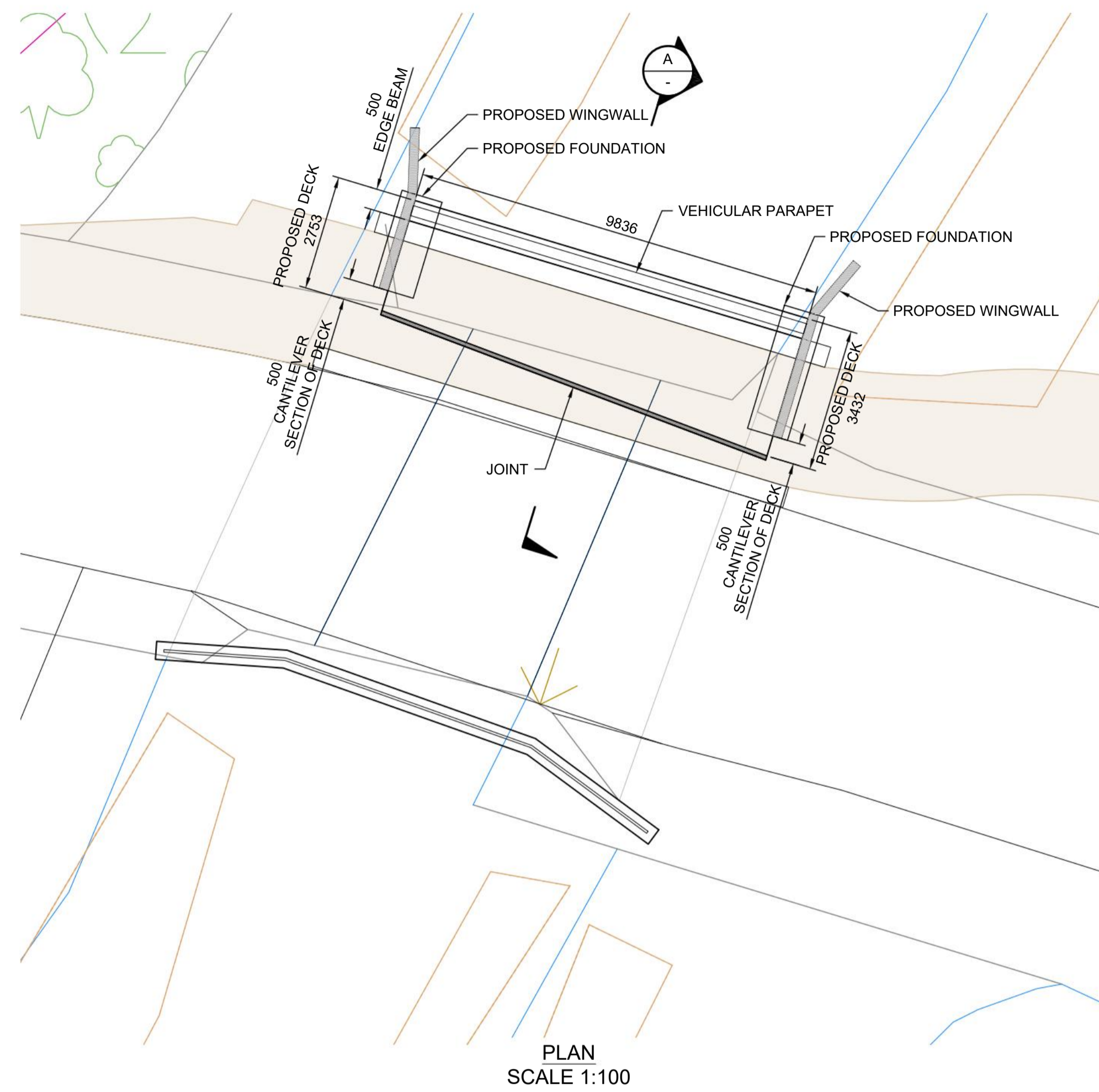
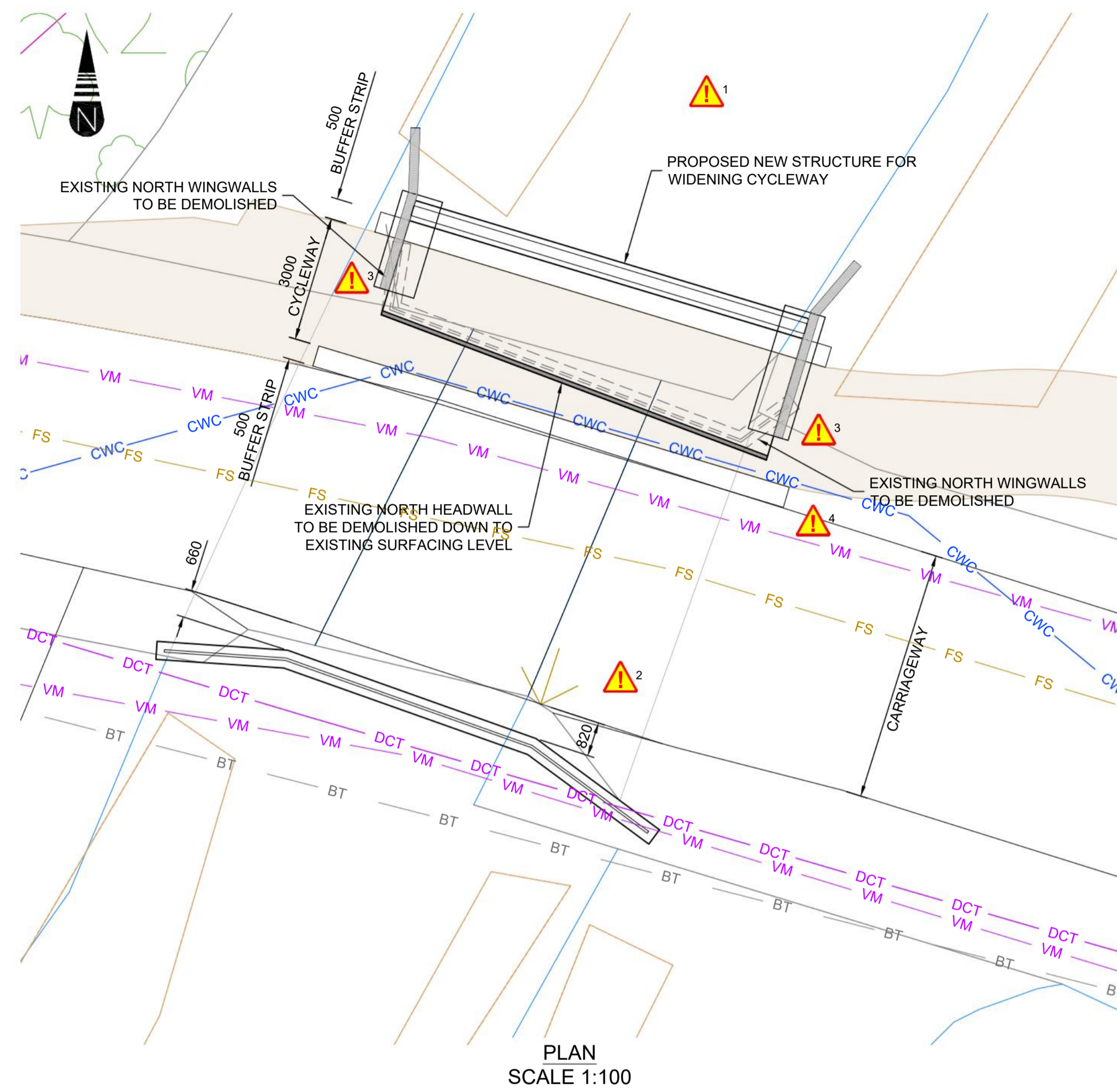

- NOTES:
- DO NOT SCALE FROM THIS DRAWING.
 - SITE VERIFY ALL DIMENSIONS PRIOR TO CONSTRUCTION.
 - REPORT ALL DISCREPANCIES TO THE DRAWING ORIGINATOR IMMEDIATELY.
 - THIS DRAWING IS TO BE READ IN CONJUNCTION WITH ALL RELEVANT DOCUMENTS AND DRAWINGS.
 - ALL DIMENSIONS SHOWN ARE IN MILLIMETRES UNLESS STATED OTHERWISE.

Residual Risk Assessment
Wherever possible, risk is designed-out of this proposal during the design process. Where this is not possible the risk is indicated by this symbol.

SIGNIFICANT CDM HEALTH & SAFETY RISKS

- WORKING NEAR WATERCOURSE.
- WORKING NEAR LIVE TRAFFIC.
- EXCAVATION NEAR EXISTING STRUCTURE.
- UTILITIES.

SERVICES KEY:
SERVICES INFORMATION IS GIVEN FOR GENERAL GUIDANCE ONLY AND MARKINGS ARE APPROXIMATE. EXISTING APPARATUS IS LOCATED IN VARIOUS DEPTHS AND MAY DEVIATE FROM MARKED ROUTES. MARKINGS IN THE PLAN REPRESENT THE FOLLOWING:

- BT BT UNDERGROUND
- VM VIRGIN MEDIA
- DCT NEO
- CWC CAMBRIDGE WATER
- FS ANGLIAN WATER FOUL SEWER

Rev	Date	Description	Drn	Chkd	App
P01	01/02/23	FIRST ISSUE		PJ	CS AC

Client
Cambridgeshire Highways



Vantage House, Vantage Park, Waddingley Road, Huntingdon, PE29 6SR.

Drawing Originator
MILESTONE INFRASTRUCTURE
A part of MGroup Services
Woodlands Court, Burnham Road, Beaconsfield, Buckinghamshire, HP9 2SF
This drawing is copyright of Milestone Infrastructure and shall not be reproduced without prior written permission.

Drawing Status
FOR INFORMATION
Project Name
RAMPTON TO COTTENHAM CYCLEWAY
Title
CULVERT B PROPOSED WIDENING

Sheet Size	Scale	Drawn by	Checked by	Approved by
A1	AS SHOWN	CS	AC	AC
		Drawn Date	Checked Date	Approved Date
		20-10-22	31-01-23	31-01-23

Drawing Number	Status	Rev
5020600-MIN-SBR-DR-CB-1202	S2	P01

© Crown copyright and database rights XXXX Ordnance Survey 100023205. You are permitted to use this data solely to enable you to respond to, or interact with, the organisation that provided you with the data. You are not permitted to copy, sub-licence, distribute or sell any of this data to third parties in any form.

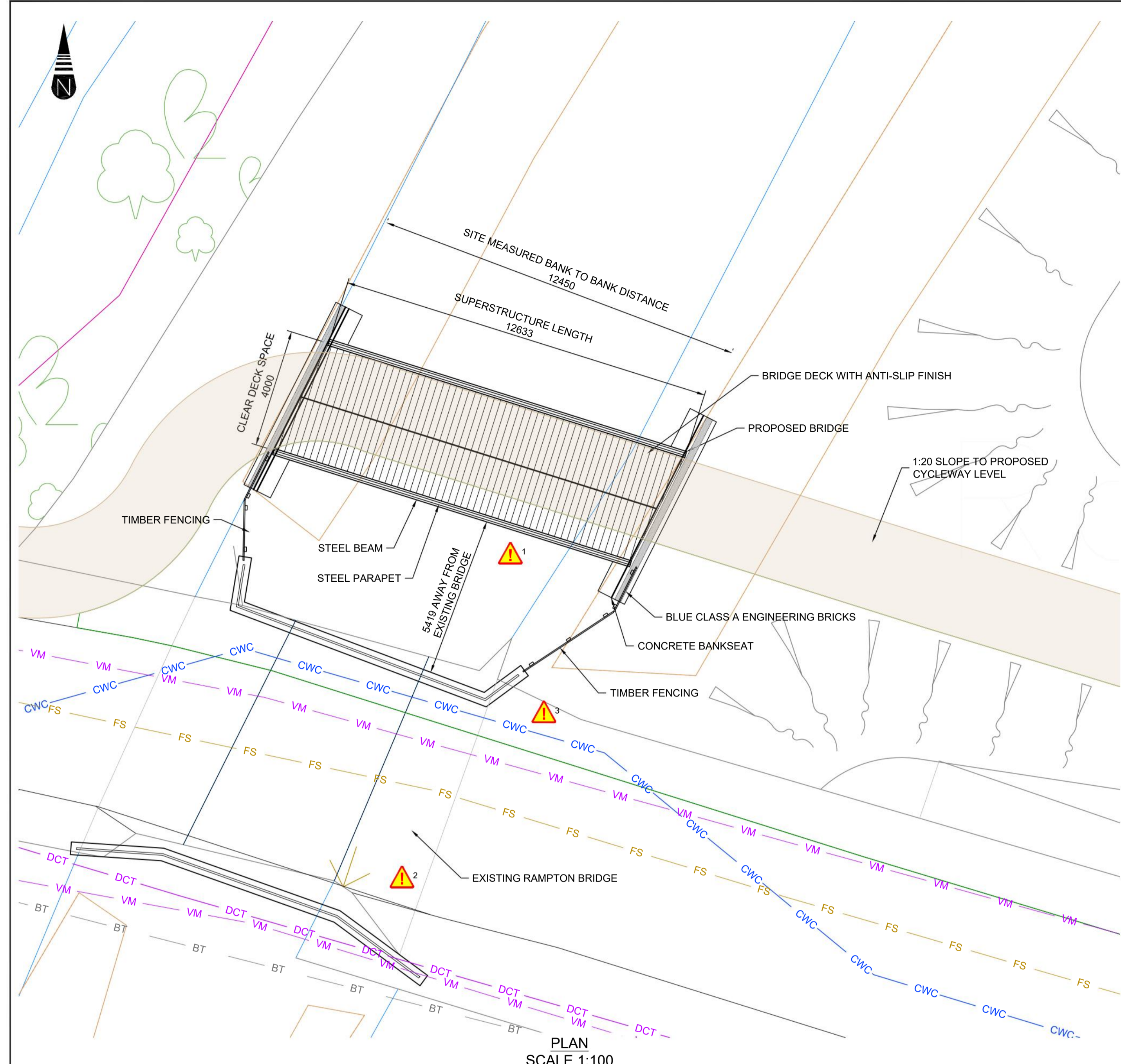

PLAN
SCALE 1:100

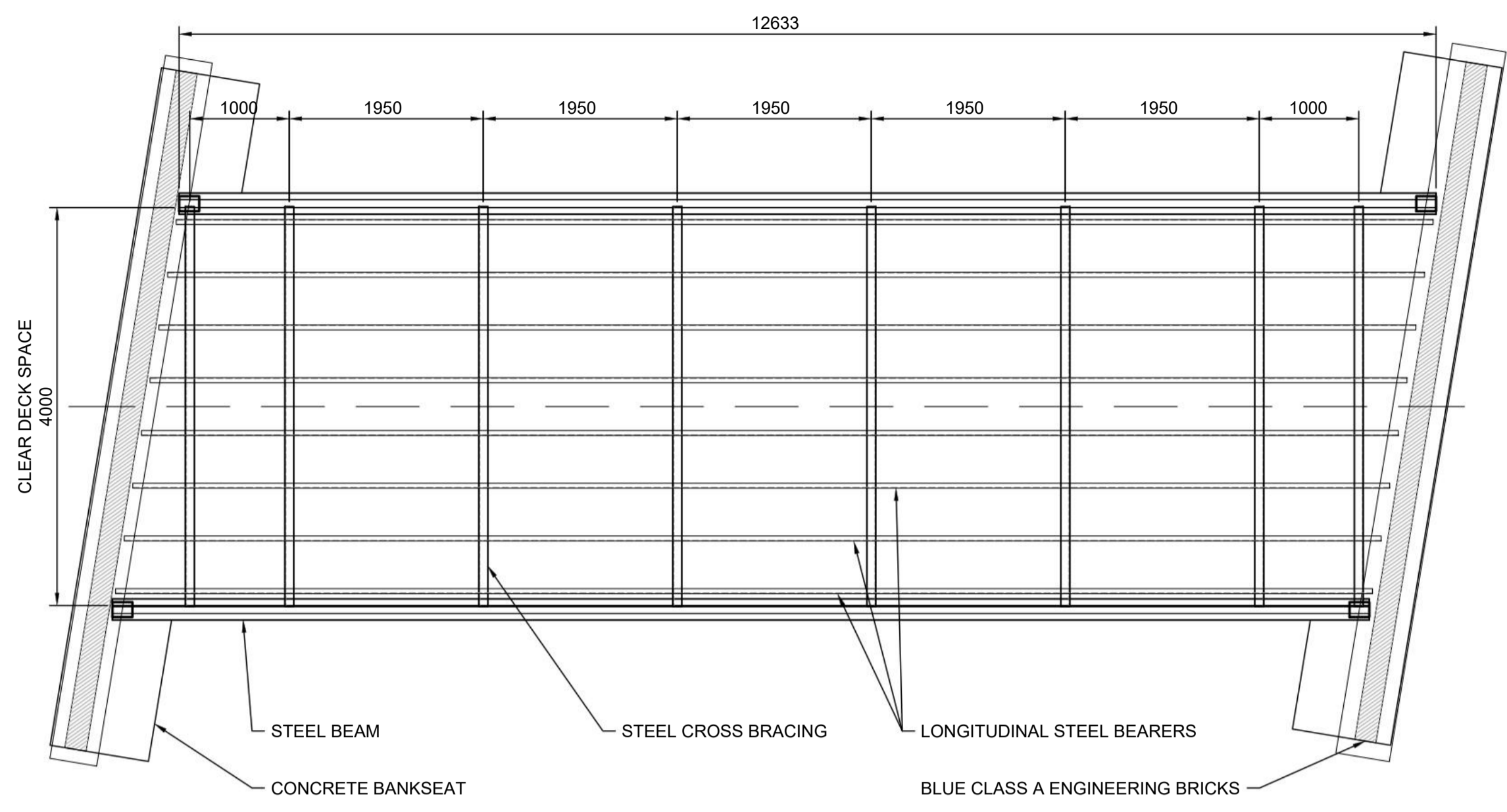

PROPOSED BRIDGE PLAN
SCALE 1:50

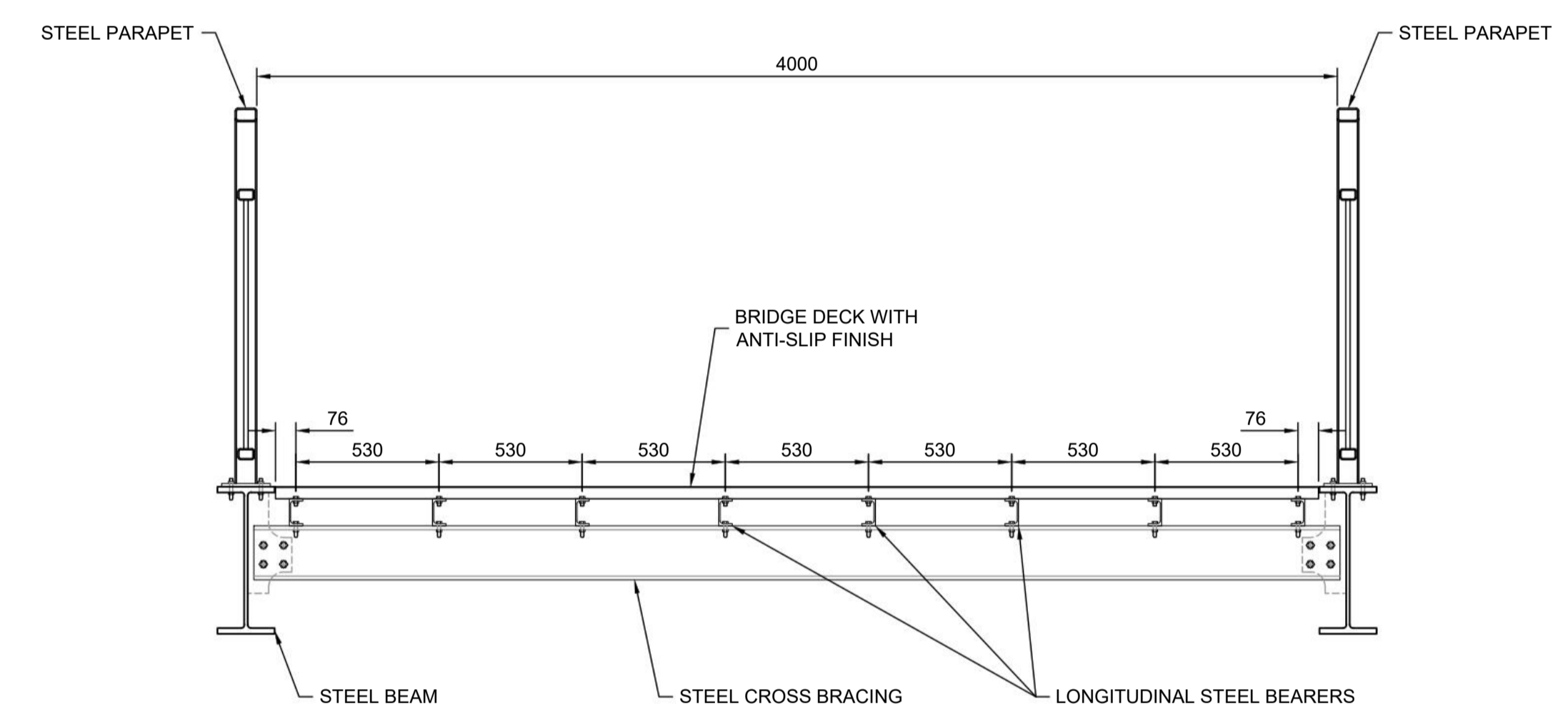

TYPICAL CROSS SECTION
SCALE 1:20

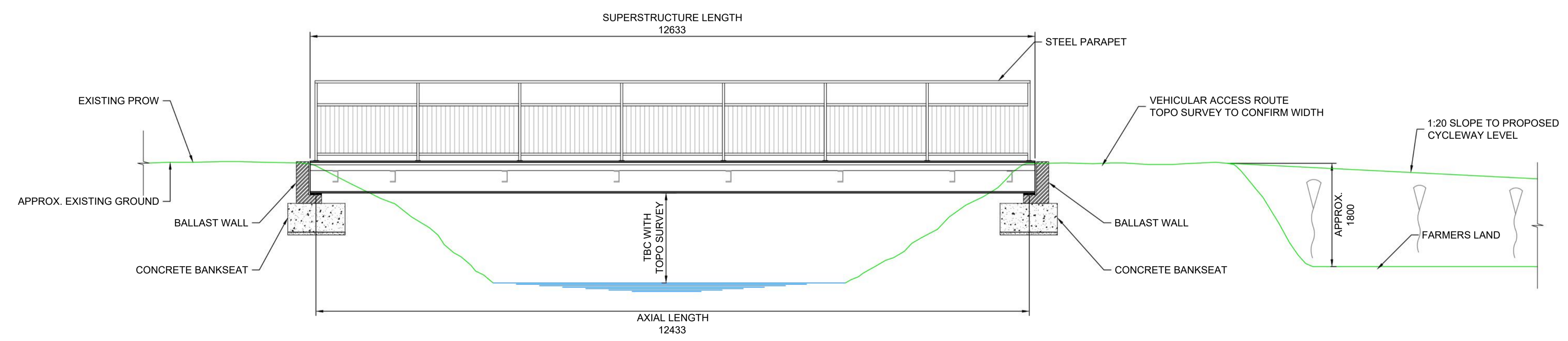

SOUTH ELEVATION
SCALE 1:50

- NOTES:
- DO NOT SCALE FROM THIS DRAWING.
 - SITE VERIFY ALL DIMENSIONS PRIOR TO CONSTRUCTION.
 - REPORT ALL DISCREPANCIES TO THE DRAWING ORIGINATOR IMMEDIATELY.
 - THIS DRAWING IS TO BE READ IN CONJUNCTION WITH ALL RELEVANT DOCUMENTS AND DRAWINGS.
 - ALL DIMENSIONS SHOWN ARE IN MILLIMETRES UNLESS STATED OTHERWISE.

Residual Risk Assessment
Wherever possible, risk is designed-out of this proposal during the design process. Where this is not possible the risk is indicated by this symbol.

SIGNIFICANT CDM HEALTH & SAFETY RISKS

- WORKING NEAR WATERCOURSE.
- WORKING NEAR LIVE TRAFFIC.
- UTILITIES.

SERVICES KEY:
SERVICES INFORMATION IS GIVEN FOR GENERAL GUIDANCE ONLY AND MARKINGS ARE APPROXIMATE. EXISTING APPARATUS IS LOCATED IN VARIOUS DEPTHS AND MAY DEVIATE FROM MARKED ROUTES. MARKINGS IN THE PLAN REPRESENT THE FOLLOWING:

- BT BT UNDERGROUND
- VM VIRGIN MEDIA
- DCT NEO
- CWC CAMBRIDGE WATER
- FS ANGLIAN WATER FOUL SEWER

Rev	Date	Description	Drn	Chkd	App
P01	01/02/23	FIRST ISSUE	PJ	CS	AC
Revisions					

Client
Cambridgeshire Highways
Cambridgeshire County Council
Vantage House, Vantage Park, Washingley Road, Huntingdon, PE29 6SR.

Drawing Originator
MILESTONE INFRASTRUCTURE
A part of MGroup Services
Woodlands Court, Burnham Road, Beaconsfield, Buckinghamshire, HP9 2SF. This drawing is copyright of Milestone Infrastructure and shall not be reproduced without prior written permission.

Drawing Status
FOR INFORMATION
Project Name
RAMPTON TO COTTENHAM CYCLEWAY

Title
CULVERT B PROPOSED NEW STRUCTURE

Sheet Size	Scale	Drawn by	Checked by	Approved by
A1	AS SHOWN	CS	AC	AC
		Drawn Date	Checked Date	Approved Date
		20-10-22	31-01-23	31-01-23

Drawing Number	Status	Rev
5020600-MIN-SBR-DR-CB-1203	S2	P01

© Crown copyright and database rights XXXX Ordnance Survey 100023205. You are permitted to use this data solely to enable you to respond to, or interact with, the organisation that provided you with the data. You are not permitted to copy, sub-licence, distribute or sell any of this data to third parties in any form.

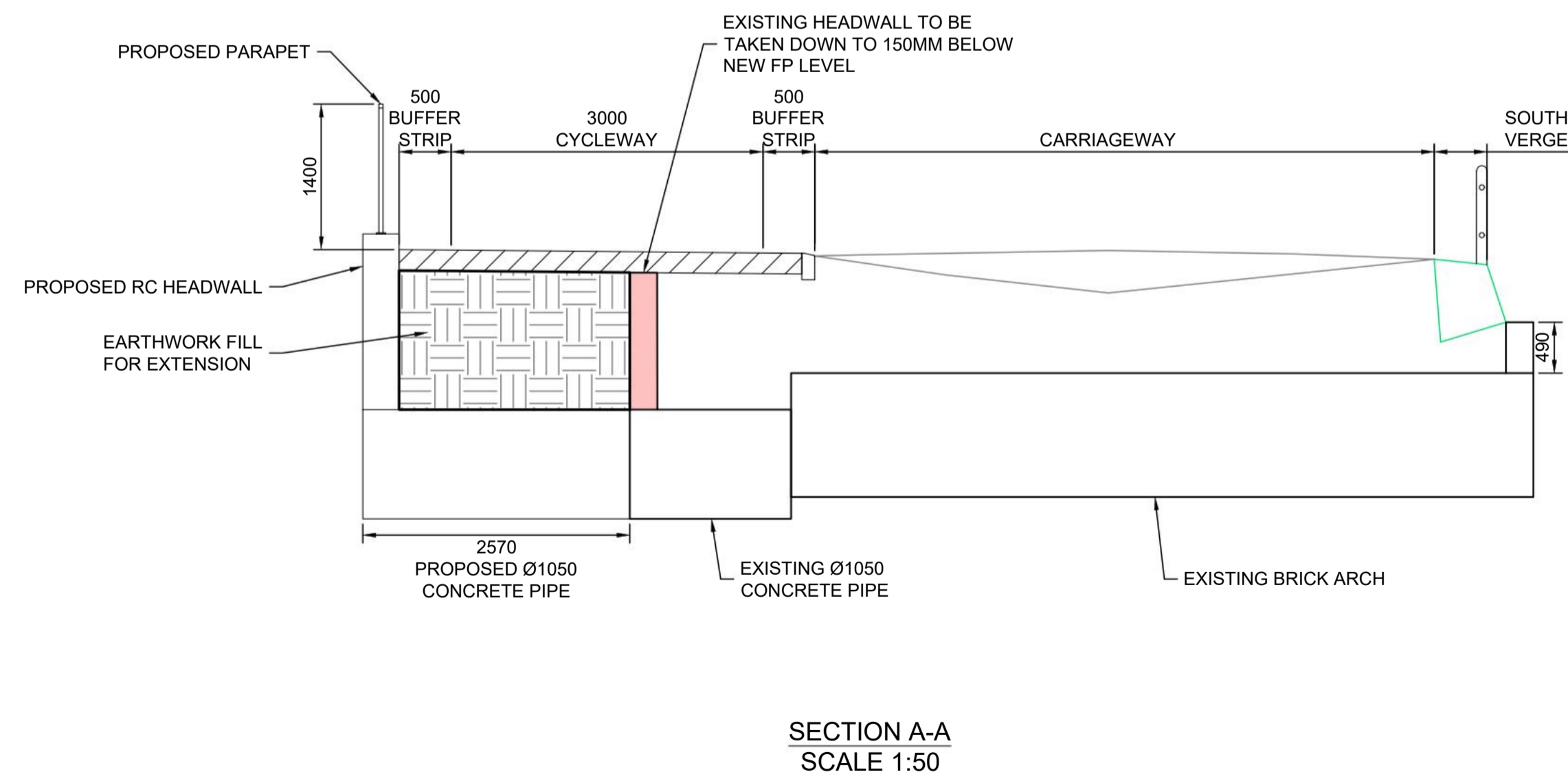
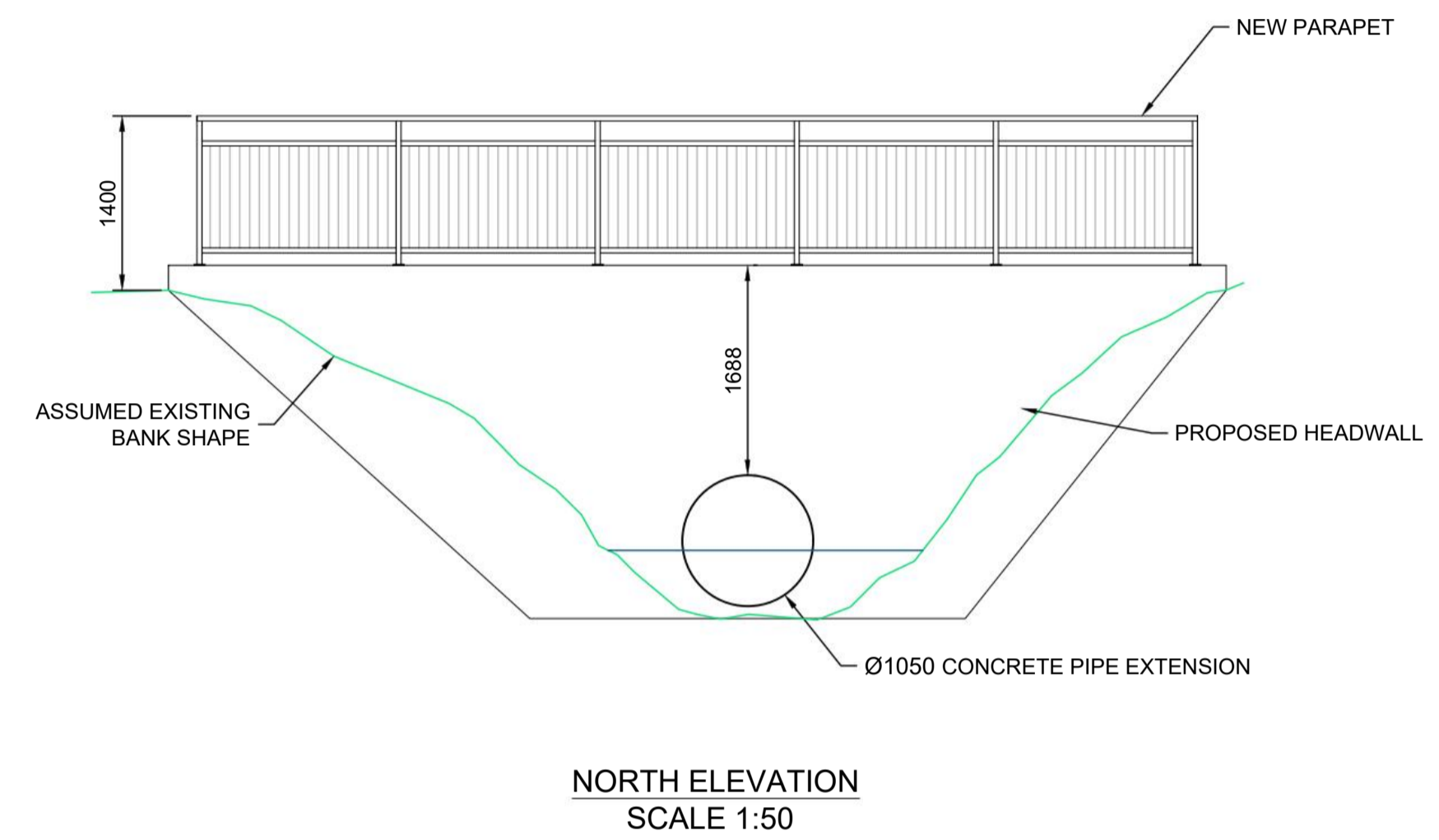
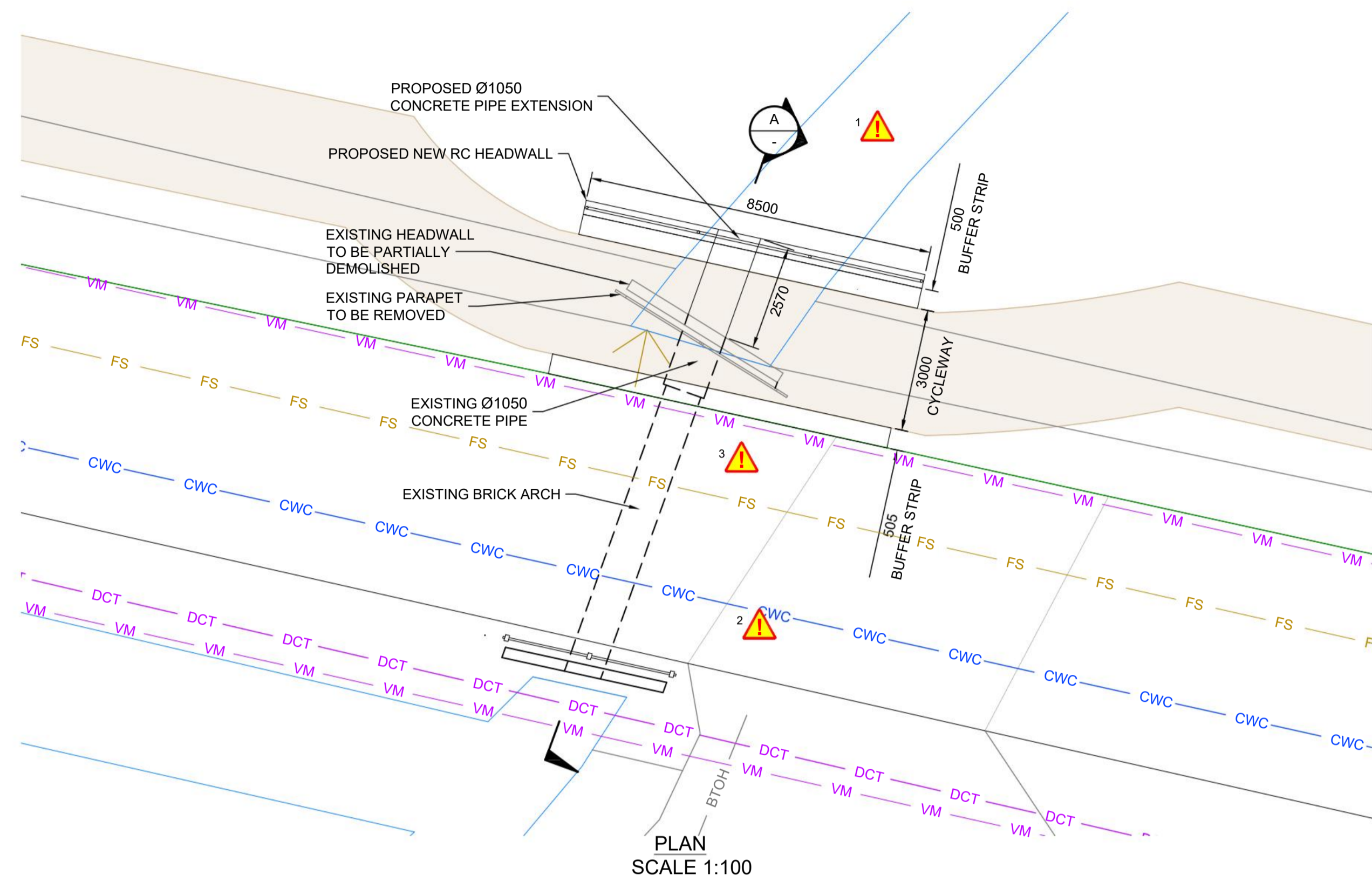

- NOTES:
- DO NOT SCALE FROM THIS DRAWING.
 - SITE VERIFY ALL DIMENSIONS PRIOR TO CONSTRUCTION.
 - REPORT ALL DISCREPANCIES TO THE DRAWING ORIGINATOR IMMEDIATELY.
 - THIS DRAWING IS TO BE READ IN CONJUNCTION WITH ALL RELEVANT DOCUMENTS AND DRAWINGS.

Residual Risk Assessment
Wherever possible, risk is designed-out of this proposal during the design process. Where this is not possible the risk is indicated by this symbol.

SIGNIFICANT CDM HEALTH & SAFETY RISKS

- WORKING NEAR WATERCOURSE.
- WORKING NEAR LIVE TRAFFIC.
- UTILITIES.

Rev	Date	Description	Drn	Chkd	App
P01	01/02/23	FIRST ISSUE	PJ	CS	AC
Revisions					

Client
Cambridgeshire Highways

Cambridgeshire County Council
Vantage House, Vantage Park, Washingley Road, Huntingdon, PE29 6SR.

Drawing Originator
MILESTONE INFRASTRUCTURE
A part of MGroup Services
Woodlands Court, Burnham Road, Beaconsfield, Buckinghamshire, HP9 2SF. This drawing is copyright of Milestone Infrastructure and shall not be reproduced without prior written permission.

Drawing Status
FOR INFORMATION

Project Name
RAMPTON TO COTTENHAM CYCLEWAY

Title
CULVERT C PROPOSED WIDENING

Sheet Size	Scale	Drawn by	Checked by	Approved by
A1	AS SHOWN	PJ	CS	AC
		Drawn Date	Checked Date	Approved Date
		20-10-22	09-01-23	31-01-23

Drawing Number	Status	Rev
5020600-MIN-SBR-DR-CB-1204	S2	P01

© CROWN COPYRIGHT AND DATABASE RIGHTS XXXX ORDNANCE SURVEY 100023205. YOU ARE PERMITTED TO USE THIS DATA SOLELY TO ENABLE YOU TO RESPOND TO, OR INTERACT WITH, THE ORGANISATION THAT PROVIDED YOU WITH THE DATA. YOU ARE NOT PERMITTED TO COPY, SUB-LICENCE, DISTRIBUTE OR SELL ANY OF THIS DATA TO THIRD PARTIES IN ANY FORM.

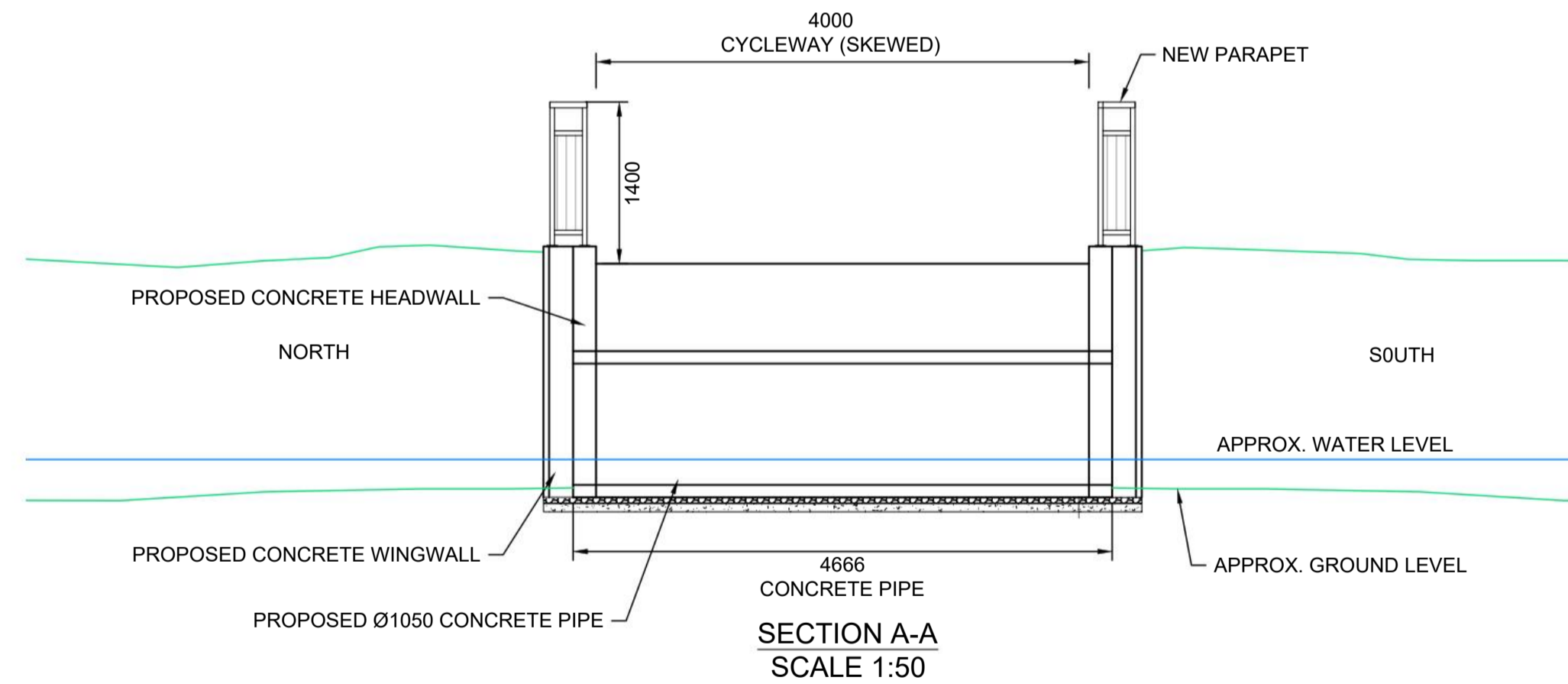
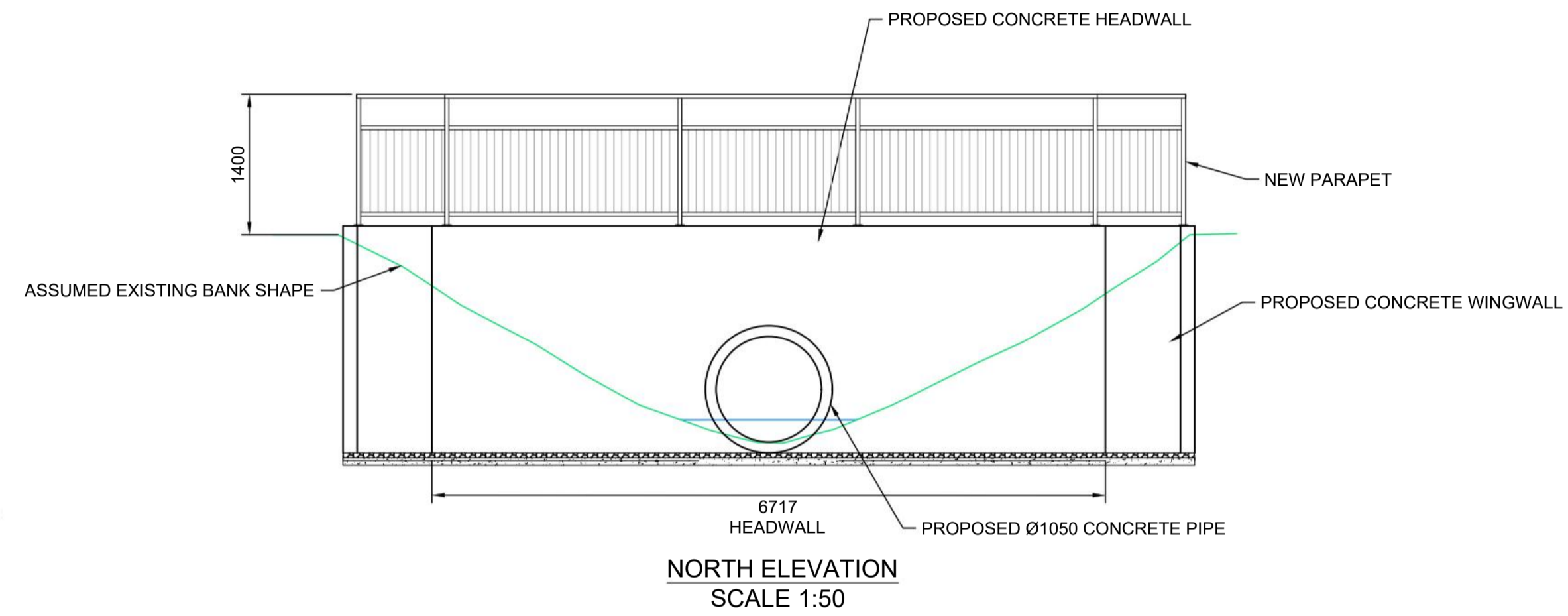
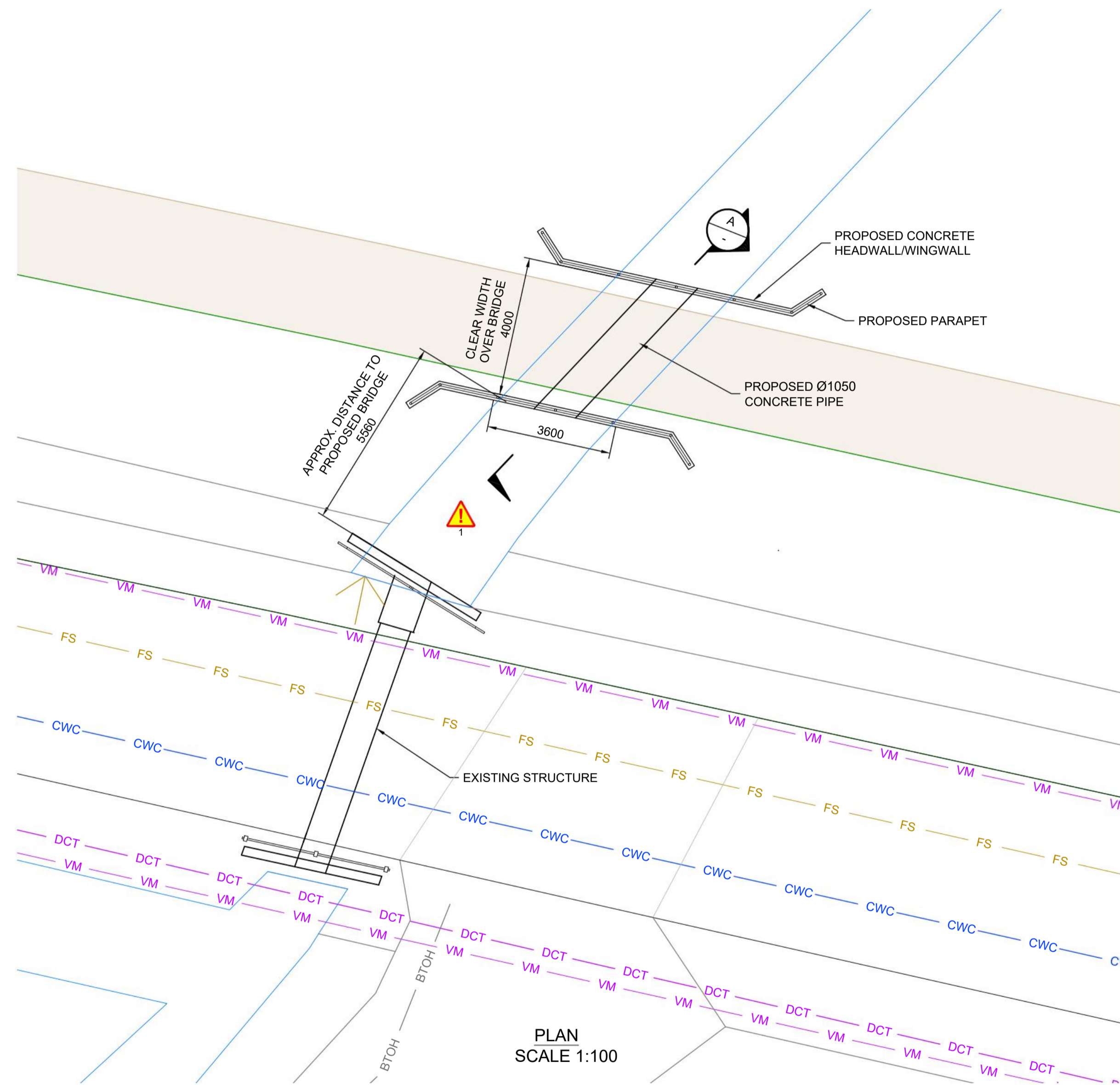

- NOTES:
- DO NOT SCALE FROM THIS DRAWING.
 - SITE VERIFY ALL DIMENSIONS PRIOR TO CONSTRUCTION.
 - REPORT ALL DISCREPANCIES TO THE DRAWING ORIGINATOR IMMEDIATELY.
 - THIS DRAWING IS TO BE READ IN CONJUNCTION WITH ALL RELEVANT DOCUMENTS AND DRAWINGS.

Residual Risk Assessment
 Wherever possible, risk is designed-out of this proposal during the design process. Where this is not possible the risk is indicated by this symbol.
SIGNIFICANT CDM HEALTH & SAFETY RISKS

1. WORKING NEAR WATERCOURSE.

Rev	Date	Description	Drn	Chkd	App
P01	01/02/23	FIRST ISSUE	PJ	CS	AC
Revisions					

Client
Cambridgeshire Highways

Cambridgeshire County Council
 Vantage House, Vantage Park
 Washingey Road, Huntingley, PE29 6SR.

Drawing Originator
MILESTONE INFRASTRUCTURE
 A part of MGroup Services
 Woodlands Court, Burnham Road
 Beaconsfield, Buckinghamshire, HP9 2SF
 This drawing is copyright of Milestone Infrastructure and shall not be reproduced without prior written permission.

Drawing Status
FOR INFORMATION
 Project Name
RAMPTON TO COTTENHAM CYCLEWAY
 Title
**CULVERT C
 PROPOSED NEW STRUCTURE
 (CULVERT)**

Sheet Size	Scale	Drawn by	Checked by	Approved by
A1	AS SHOWN	PJ	CS	AC
		Drawn Date	Checked Date	Approved Date
		20-10-22	09-01-23	31-01-23

Drawing Number	Status	Rev
5020600-MIN-SBR-DR-CB-1205A	S2	P01

© CROWN COPYRIGHT AND DATABASE RIGHTS XXXX ORDNANCE SURVEY 100023205. YOU ARE PERMITTED TO USE THIS DATA SOLELY TO ENABLE YOU TO RESPOND TO, OR INTERACT WITH, THE ORGANISATION THAT PROVIDED YOU WITH THE DATA. YOU ARE NOT PERMITTED TO COPY, SUB-LICENCE, DISTRIBUTE OR SELL ANY OF THIS DATA TO THIRD PARTIES IN ANY FORM.

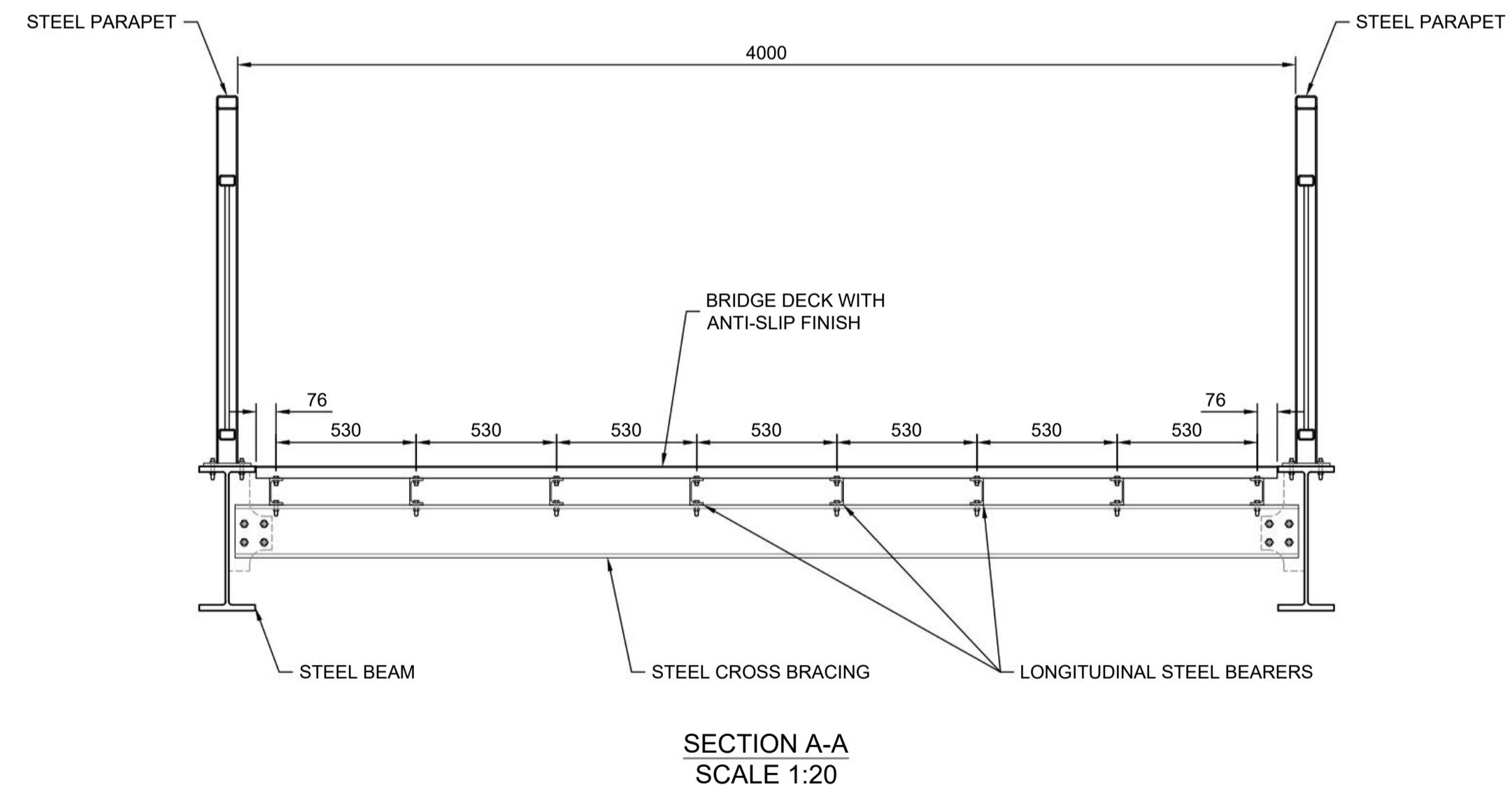
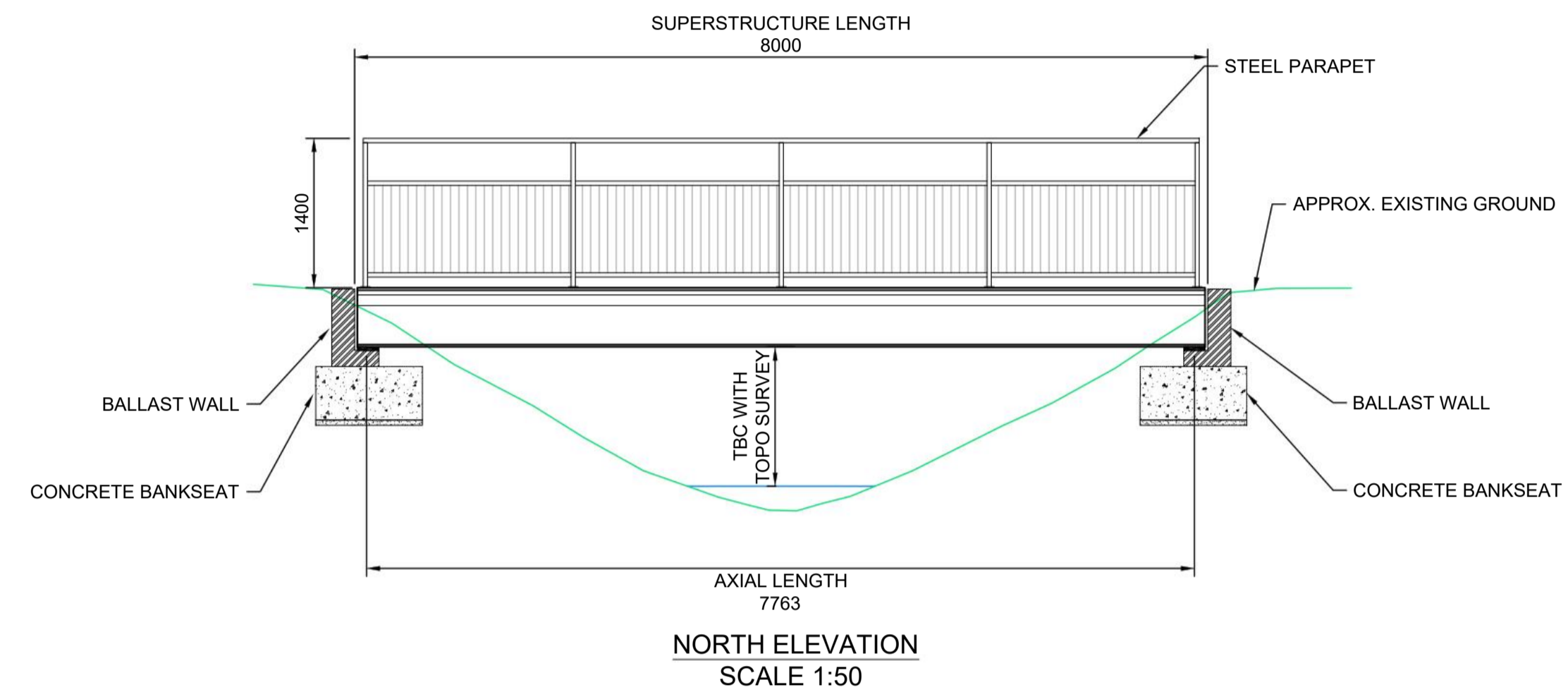
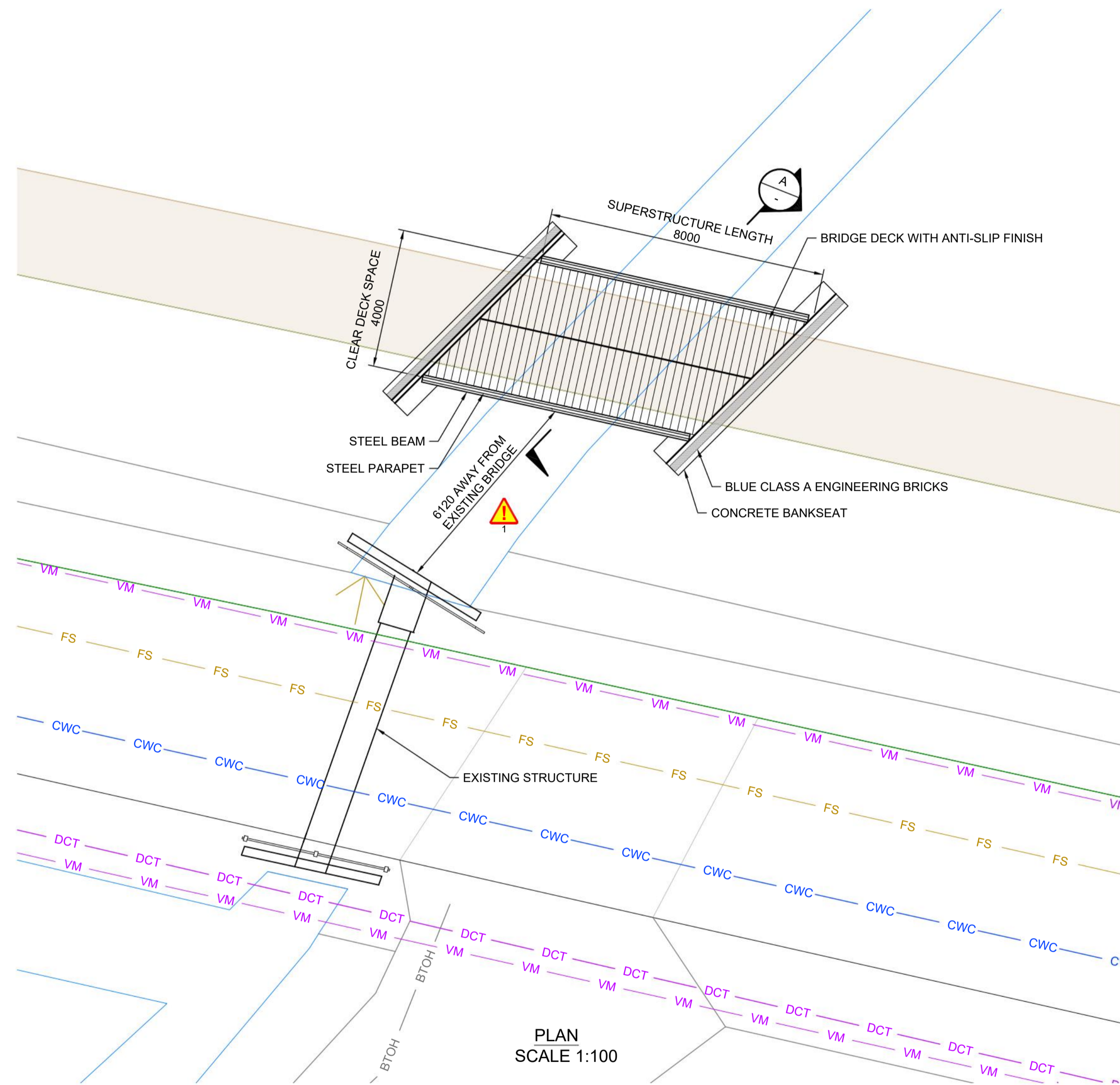

- NOTES:
- DO NOT SCALE FROM THIS DRAWING.
 - SITE VERIFY ALL DIMENSIONS PRIOR TO CONSTRUCTION.
 - REPORT ALL DISCREPANCIES TO THE DRAWING ORIGINATOR IMMEDIATELY.
 - THIS DRAWING IS TO BE READ IN CONJUNCTION WITH ALL RELEVANT DOCUMENTS AND DRAWINGS.

Residual Risk Assessment
Wherever possible, risk is designed-out of this proposal during the design process. Where this is not possible the risk is indicated by this symbol. 
SIGNIFICANT CDM HEALTH & SAFETY RISKS
1. WORKING NEAR WATERCOURSE.

Rev	Date	Description	Drn	Chkd	App
P01	01/02/23	FIRST ISSUE	PJ	CS	AC

Revisions

Client
Cambridgeshire Highways

Cambridgeshire County Council
Vantage House, Vantage Park, Washingley Road, Huntingdon, PE29 6SR.

Drawing Originator
MILESTONE INFRASTRUCTURE
A part of MGroup Services
Woodlands Court, Burnham Road, Beaconsfield, Buckinghamshire, HP9 2SF. This drawing is copyright of Milestone Infrastructure and shall not be reproduced without prior written permission.

Drawing Status
FOR INFORMATION

Project Name
RAMPTON TO COTTENHAM CYCLEWAY

Title
**CULVERT C
PROPOSED NEW STRUCTURE
(FOOTBRIDGE)**

Sheet Size	Scale	Drawn by	Checked by	Approved by
A1	AS SHOWN	PJ	CS	AC
		Drawn Date	Checked Date	Approved Date
		20-10-22	09-01-23	31-01-23

Drawing Number	Status	Rev
5020600-MIN-SBR-DR-CB-1205B	S2	P01

© CROWN COPYRIGHT AND DATABASE RIGHTS XXXX ORDNANCE SURVEY 100023205. YOU ARE PERMITTED TO USE THIS DATA SOLELY TO ENABLE YOU TO RESPOND TO, OR INTERACT WITH, THE ORGANISATION THAT PROVIDED YOU WITH THE DATA. YOU ARE NOT PERMITTED TO COPY, SUB-LICENCE, DISTRIBUTE OR SELL ANY OF THIS DATA TO THIRD PARTIES IN ANY FORM.

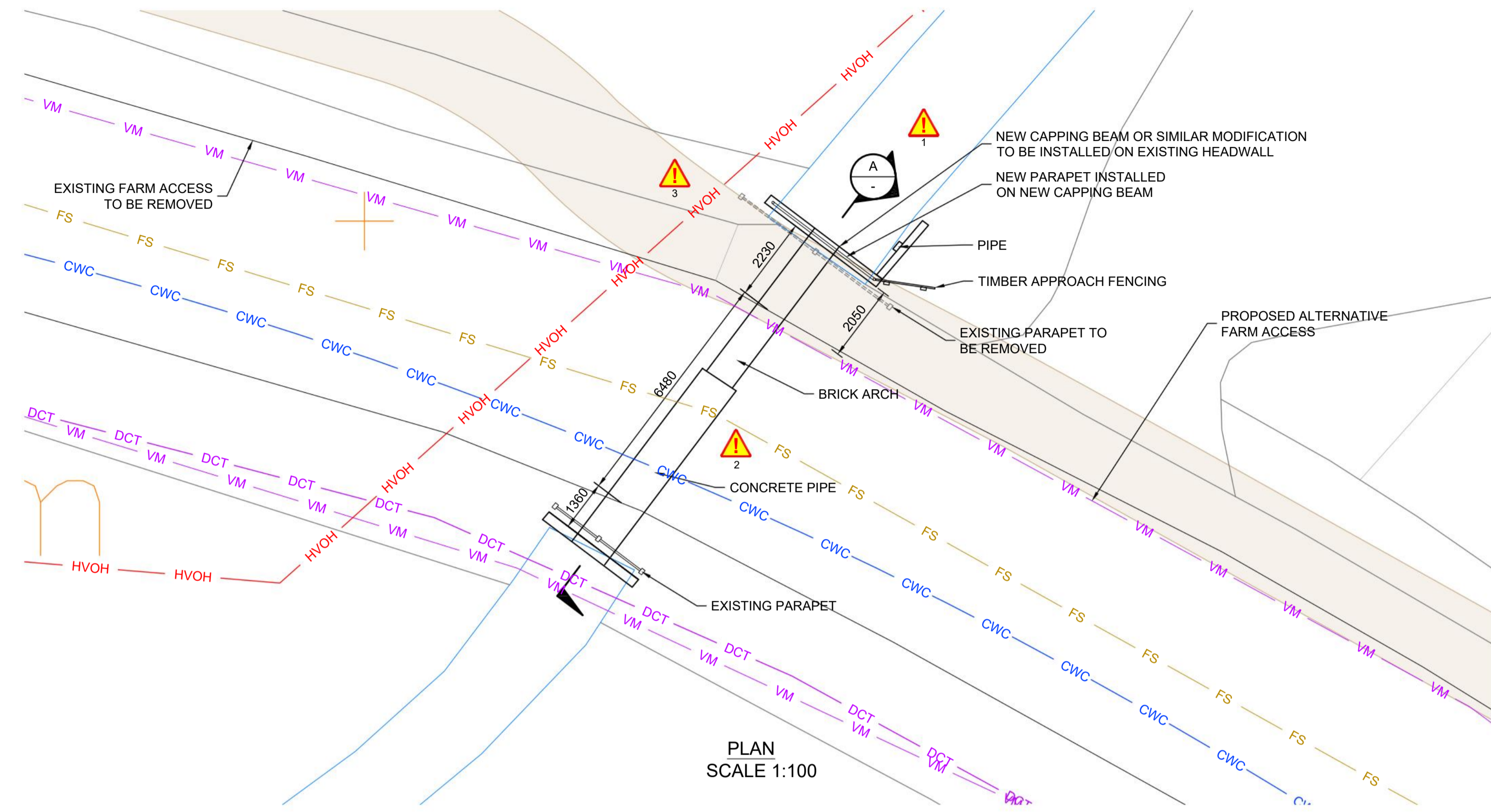

PLAN
SCALE 1:100

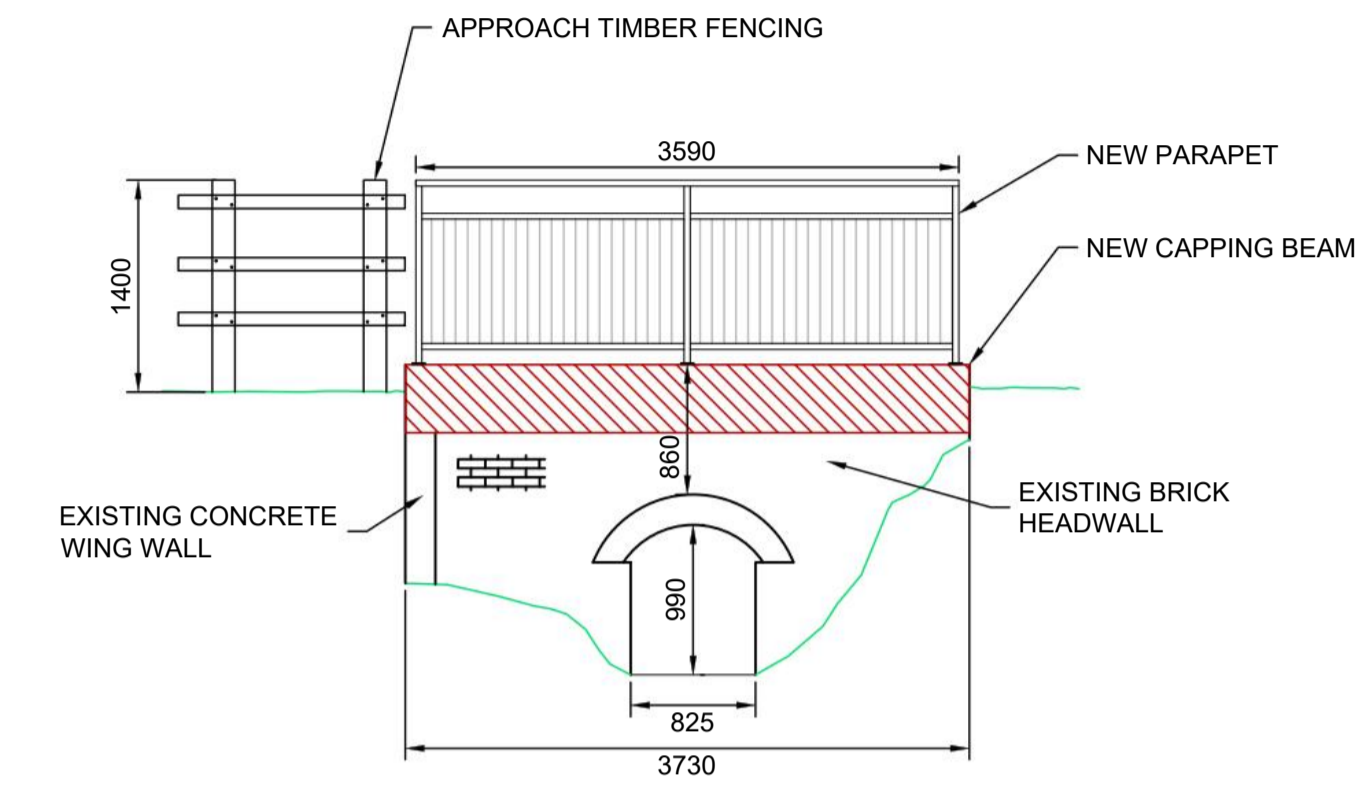

NORTH ELEVATION
SCALE 1:50

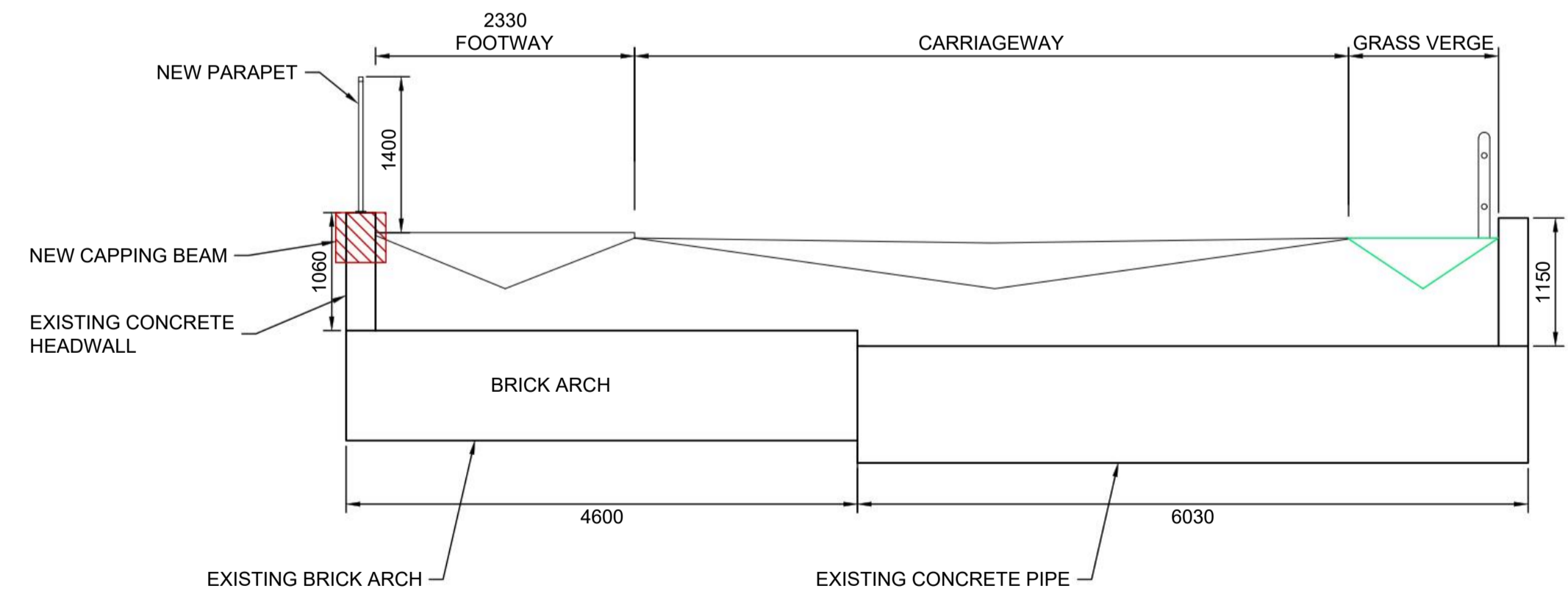

SECTION A-A
SCALE 1:50

- NOTES:
- DO NOT SCALE FROM THIS DRAWING.
 - SITE VERIFY ALL DIMENSIONS PRIOR TO CONSTRUCTION.
 - REPORT ALL DISCREPANCIES TO THE DRAWING ORIGINATOR IMMEDIATELY.
 - THIS DRAWING IS TO BE READ IN CONJUNCTION WITH ALL RELEVANT DOCUMENTS AND DRAWINGS.

Residual Risk Assessment
Wherever possible, risk is designed-out of this proposal during the design process. Where this is not possible the risk is indicated by this symbol. 
SIGNIFICANT CDM HEALTH & SAFETY RISKS

- WORKING NEAR WATERCOURSE.
- WORKING NEAR LIVE TRAFFIC.
- UTILITIES.

Rev	Date	Description	Drn	Chkd	App
P01	01/02/23	FIRST ISSUE		PJ	CS AC
Revisions					

Client
Cambridgeshire Highways
Cambridgeshire County Council
Vantage House, Vantage Park, Washingley Road, Huntingdon, PE29 6SR.

Drawing Originator
MILESTONE INFRASTRUCTURE
A part of MGroup Services
Woodlands Court, Burnham Road, Beaconsfield, Buckinghamshire, HP9 2SF. This drawing is copyright of Milestone Infrastructure and shall not be reproduced without prior written permission.

Drawing Status
FOR INFORMATION
Project Name
RAMPTON TO COTTENHAM CYCLEWAY

Title
CULVERT D PROPOSED WIDENING
DRAFT

Sheet Size	Scale	Drawn by	Checked by	Approved by
A1	AS SHOWN	PJ	CS	AC
		Drawn Date	Checked Date	Approved Date
		26-10-22	09-01-23	31-01-23

Drawing Number	Status	Rev
5020600-MIN-SBR-DR-CB-1206	S2	P01

© CROWN COPYRIGHT AND DATABASE RIGHTS XXXX ORDNANCE SURVEY 100023205. YOU ARE PERMITTED TO USE THIS DATA SOLELY TO ENABLE YOU TO RESPOND TO, OR INTERACT WITH, THE ORGANISATION THAT PROVIDED YOU WITH THE DATA. YOU ARE NOT PERMITTED TO COPY, SUB-LICENCE, DISTRIBUTE OR SELL ANY OF THIS DATA TO THIRD PARTIES IN ANY FORM.

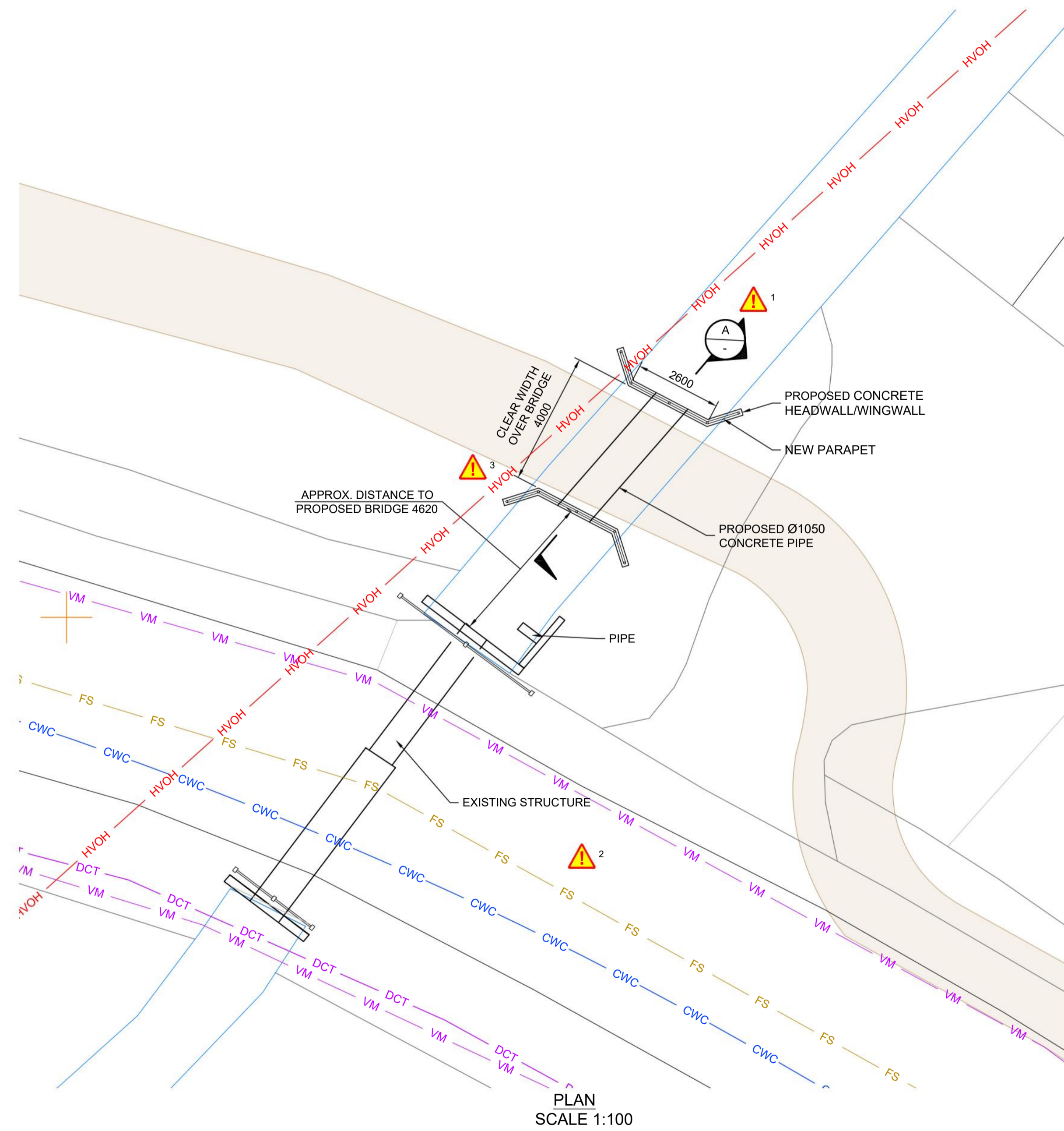

© CROWN COPYRIGHT AND DATABASE RIGHTS XXXX ORDNANCE SURVEY 100023205. YOU ARE PERMITTED TO USE THIS DATA SOLELY TO ENABLE YOU TO RESPOND TO, OR INTERACT WITH, THE ORGANISATION THAT PROVIDED YOU WITH THE DATA. YOU ARE NOT PERMITTED TO COPY, SUB-LICENSE, DISTRIBUTE OR SELL ANY OF THIS DATA TO THIRD PARTIES IN ANY FORM.

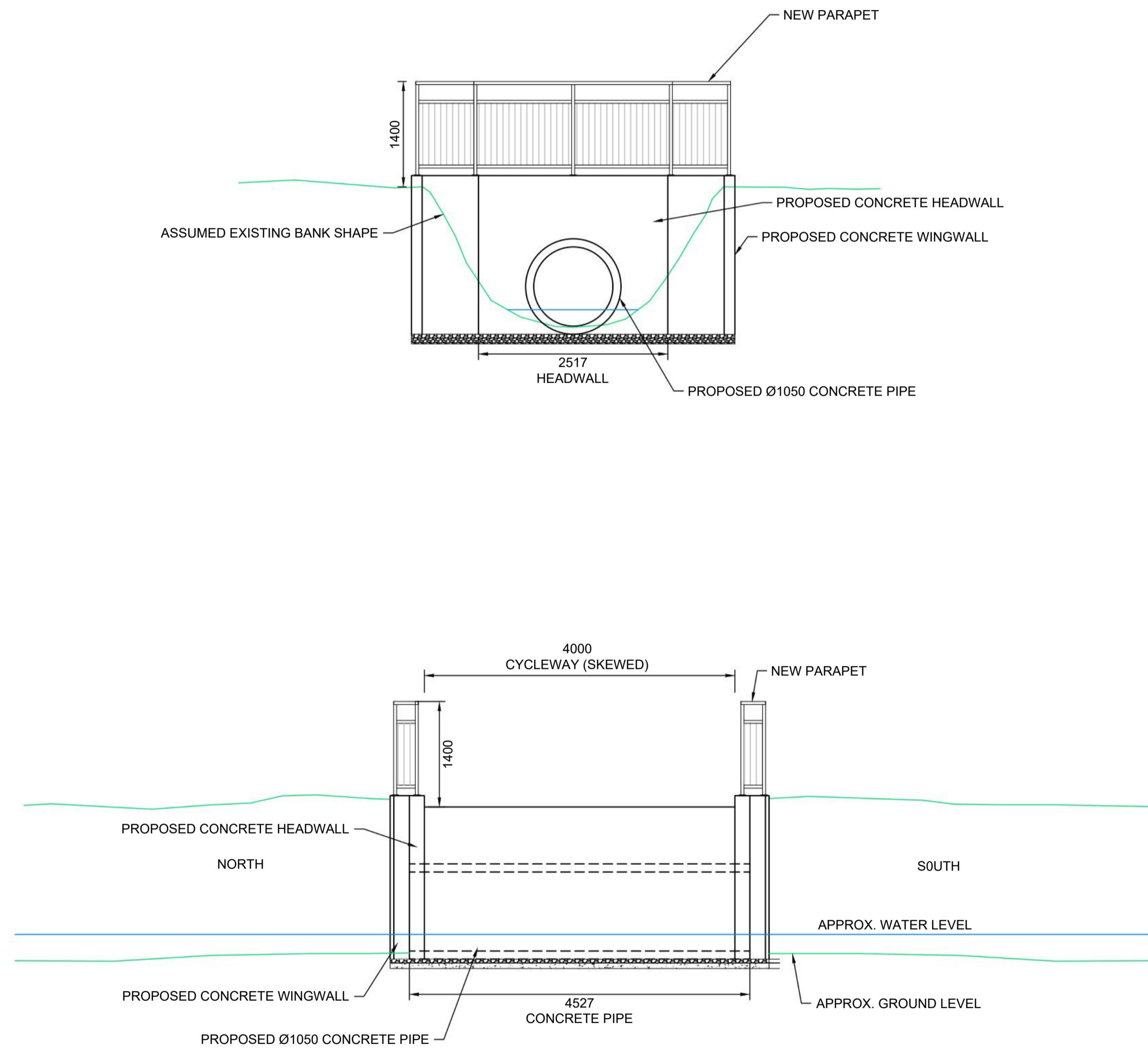

- NOTES:
- DO NOT SCALE FROM THIS DRAWING.
 - SITE VERIFY ALL DIMENSIONS PRIOR TO CONSTRUCTION.
 - REPORT ALL DISCREPANCIES TO THE DRAWING ORIGINATOR IMMEDIATELY.
 - THIS DRAWING IS TO BE READ IN CONJUNCTION WITH ALL RELEVANT DOCUMENTS AND DRAWINGS.

Residual Risk Assessment
Wherever possible, risk is designed-out of this proposal during the design process. Where this is not possible the risk is indicated by this symbol. 

SIGNIFICANT CDM HEALTH & SAFETY RISKS

- WORKING NEAR WATERCOURSE.
- WORKING NEAR LIVE TRAFFIC.
- UTILITIES.

Rev	Date	Description	Drn	Chkd	App
P01	01/02/23	FIRST ISSUE		PJ	CS AC
Revisions					

Client
Cambridgeshire Highways

Woodlands Court, Burnham Road, Beaconsfield, Buckinghamshire, HP9 2SF
Wantage House, Wantage Park, Washingley Road, Huntingdon, PE29 6SR

Drawing Originator
MILESTONE INFRASTRUCTURE
A part of **MGroup Services**

FOR INFORMATION
Project Name
RAMPTON TO COTTENHAM CYCLEWAY

Title
CULVERT D PROPOSED NEW STRUCTURE

Sheet Size	Scale	Drawn by	Checked by	Approved by
A1	AS SHOWN	PJ	CS	AC
		Drawn Date	Checked Date	Approved Date
		26-10-22	09-01-23	31-01-23

Drawing Number	Status	Rev
5020600-MIN-SBR-DR-CB-1207	S2	P01

Appendix 4 – Design Environmental Assessment

CH F802 (IS11-FO01): Design Environmental Assessment

This Design Environmental Assessment will identify environmental risks and opportunities early on and enable the Design Team to allow for specialist environmental tasks in the scope, programme, and budget.

To complete the assessment all questions must be completed by the design team (Part 1) and sent to the Environmental Team to review (Part 2). This is an iterative process, and any changes/updates must be added when available. The project manager has the overall responsibility for the completion and final sign off.

Following this assessment, permitting/constraint requirements can be addressed and mitigated within the Construction Environmental Management Plan.

The [Environmental GIS](#) contains data which should help to complete this assessment.

Please note that this assessment does not cover Local Authority Planning requirements.

Answer ALL questions to complete this section

Scheme Details

Scheme Job No.	5020600	Originator	TBC
Task Order Ref No.	TBC	Proposed Works Start Date	TBC
Scheme Title.	Rampton to Cottenham footway widening	Works Duration	Click here to enter a date.
Location.	CB24 8UL X = 544641 Y = 267154		
Proposed Scope of Works.	The project is a Feasibility study for the improvement of the pedestrian and cycling link between Rampton and Cottenham. This study will investigate the widening of the existing footway / shared use area, along Church End / Rampton Road. It will include an options report with proposal drawings for the route and the two cycle bridges along Rampton Road with estimated costs for a future scheme.		
Site Drawing References and Links	Please provide a site location plan, any relevant design drawings, and diversion routes		
Any Night-Time Working?	TBC		

Printed copies of this document are not controlled. The master document is controlled electronically. Document users are responsible for ensuring printed copies are valid prior to use.

Document Control						
Revision	Date	Description	Prepared by (Design Team)	Prepared by (Environment Team)	Checked by	Approved by
P01	08/12/2022	First Issue	HL			

Printed copies of this document are not controlled. The master document is controlled electronically. Document users are responsible for ensuring printed copies are valid prior to use.

Summary

To be completed by the Environment Team after completion of Design Environmental Assessment (IS11-FO01).

Is Statutory EIA required after initial appraisal? <input type="checkbox"/>	Design Environmental Assessment required? <input type="checkbox"/>	Ecological Survey Required? <input type="checkbox"/>
It is recommended to consult the Environment Team on completion of Part 1 and then Part 2.		

Sub-topic	Brief detail	Actions Required
1. 'Relevant Project' Screening	Statutory EIA not required	No further actions required
2. Air Quality		
3. Cultural Heritage		
4. Landscape		
5. Biodiversity		
6. Geology and Soils		
7. Material Assets and Waste		
8. Noise and Vibration		
9. Population and Human Health (Effects on the Community)		
10. Road Drainage and the Water Environment		
11. Climate		
12. Opportunities		

1. Initial EIA Appraisal

This section will determine whether the works are Schedule 1 or 2 and therefore if Statutory EIA will be required.

Part 1	A - <u>Schedule 1</u>:	
	(i) Is the proposed development Schedule 1, meeting either of the below criteria?	
	<ul style="list-style-type: none"> - Motorway or express road. - Construction of a road of four or more lanes to be at least 10km in length. - Realignment/widening from at least two lanes to four or more, at least 10 kilometres in length. 	
	Yes	<input type="checkbox"/> Statutory EIA may be required – contact Environment Team.
	No	<input checked="" type="checkbox"/> Go to Part B - Schedule 2
	B - <u>Schedule 2</u>:	
	(i) Is the proposed development Schedule 2, meeting either of the below criteria?	
	<ul style="list-style-type: none"> - Road over 1 hectare in area. - A change or extension to any former Schedule 1 development. - Motorway service area. - Industrial estate development projects over 0.5 Ha. 	
	Yes	<input type="checkbox"/> Statutory EIA may be required – contact Environment Team.
	No	<input checked="" type="checkbox"/> Statutory EIA not required.
(ii) Is the development within or near a sensitive area (an SSSI, National Park, World Heritage Site, Scheduled Monument, AON, SPA, SAC or RAMSAR)?		
Yes	<input type="checkbox"/> Statutory EIA may be required – contact Environment Team.	
No	<input type="checkbox"/> Statutory EIA not required.	
<i>Design Team Notes – if the scheme meets any EIA conditions, state below which development from the Schedules <u>1</u> & <u>2</u> criteria above</i>		

2. Air Quality

Part 1	2.1	Is scheme including any diversion routes, inside an Air Quality Management Area (AQMA) ?	No
	2.2	Will the scheme change road alignment by 5m or more?	No
	2.3	Will the scheme result in permanent change to traffic flow, parking, or speeds?	No
	2.4	Will the site duration exceed 6 months?	Yes - air quality management plan may be required.
	2.5	Will heavy plant be required over prolonged periods of time?	Yes - consider electric plant and try to reduce vehicle movements.
	2.6	Will the works produce dust?	Yes - implement dust suppression.
<p>Design Team Notes – provide detail where possible (diversion routes, site duration, expected plant etc)</p> <p>The existing path is to be broken out, so small / medium sized plant will be required. No major earthwork activities are expected during construction.</p>			
Part 2	Environment Team Assessment		

3. Cultural Heritage

Part 1	3.1	Is the scheme within a World Heritage Site, Registered Park & Garden, Historic Battlefield or Area of Archaeological or Historical Importance ?	Yes - contact Historic England and Local Authority. Design will need to avoid changes to the existing setting.
	3.2	Does the scheme propose work to or in close proximity to a listed structure/ scheduled monument ?	Yes - contact Historic England/Local Authority. Design will need to avoid changes to the existing setting.
	3.3	Will the scheme require excavation outside the existing development footprint on previously undisturbed land?	Yes - consider the potential to unearth uncharted archaeological remains. Contact Local Authority.
	3.4	Will the scheme result in long term change to current visual condition including signage, surface, structures or vegetation near cultural heritage features?	Yes - further assessment required. Contact Local Authority
	3.5	Is the scheme within a Conservation Area (not all data available via EGIS)?	Data not available - contact Local Authority/Conservation Officer for information.
<p>Design Team Notes – provide detail where possible (material type, methods, excavation depths etc)</p> <p>3.1: Giant’s Hill Moat – The adjacent hedge is protected, so no major changes are proposed along this section, apart from general maintenance to trim the hedge back to the edge of path.</p> <p>3.2: Tower mill is a Listed building, sited within 60m of Rampton Road. This isn’t immediately affected by the design.</p> <p>3.3: Both option 1 & 2 require land take beyond the Highway boundary.</p> <p>3.4: Existing signs are to be relocated, and new signs installed. Option 1 requires the removal of the existing hedge line, and new verges. However, replacement planting can be incorporated into the separation strip.</p>			
Part 2	<p>Environment Team Assessment</p>		

4. Landscape

Part 1	4.1	Will the scheme require vegetation clearance, or excavations within the verges?	Yes - discuss with Environment Team. Consider replacement planting where possible and appropriate.
	4.2	Is any tree affected by the works subject to a Tree Preservation Order or located in a Conservation Area (not all data available via EGIS)? Trees in Conservation Areas are protected if stem diameter is > 75mm.	Data not available - contact Local Authority for information.
	4.3	Will more than 5 cubic metres of trees be felled?	No - contact Local Authority/Tree Officer
	4.4	Will the scheme involve works that will impact upon trees and their root protection areas (roughly, RPA radius = trunk diameter x 12)?	No
	4.5	Are any hedgerows to be removed?	Yes - notify Local Authority to check if hedge is protected (hedge can be removed if no response within 42 days). Consider replanting with a diverse specification.
	4.6	Is the scheme situated within or adjacent to a designated site such as an Area of Outstanding National Beauty, National Park or Registered Park and Gardens ?	No
	4.7	Will the scheme result in long term change to current visual condition incl. lighting, signage, structures, removal of vegetation?	Yes - consult with relevant statutory bodies and/or consider effects on local landscape.
	4.8	Does the scheme propose landscaping (re-profiling, infilling, excavation etc)?	Yes - consult Landscape or Environment Team.
<p>Design Team Notes - provide detail where possible (material choices, surroundings, receptors etc)</p> <p>4.1: Excavation required in existing verges for new pavement construction.</p> <p>4.2: Existing tree and bus shelter located adjacent to 'the Grn' (identified on the on-drawing plans) are to be maintained rather than removed, with footway pinch points.</p> <p>4.5: Option 1 – The existing hedge row is to be removed.</p> <p>4.7: Existing signs are to be relocated, and new signs installed. Option 1 requires the removal of the existing hedge line, and new verges. However, replacement planting can be incorporated into the separation strip.</p> <p>4.8: Excavation required during construction process.</p>			
Part 2	Environment Team Assessment		

5. Biodiversity

Part 1	5.1	Has an ecological walkover been undertaken?	No - an ecological walkover with a qualified person may be required.
	5.2	Will the scheme require vegetation clearance, excavations, or movement of plant within verges or riverbanks?	Yes - consult Environment Team as an ecological walkover may be required.
	5.3	Will the works be within 200m of a sensitive area (SPA, SAC, SSSI, NNR, LNR or Ramsar site or their impact risk zone)?	Yes - consult Natural England. Screening for appropriate assessment may also be required.
	5.4	Will the scheme impact voids, joints or crevices (in trees, bridges, buildings etc)?	No
	5.5	Will there be works to a Roadside Verge Nature Reserve ?	No
	5.6	Will works require use of noisy or vibratory plant?	Yes - if site is sensitive, consult Environment Team to consider potential disturbance of species.
	5.7	Will the scheme require any change to volume, flow or water quality?	No
<p>Design Team Notes – provide detail where possible (timeframes for nesting seasons, vegetation plans etc)</p> <p>5.2: Existing hedge line to be removed in option 1.</p> <p>5.3: Existing Pond located approx. 80m from church lane. This isn't impacted directly by the scheme.</p>			
Part 2	<p>Environment Team Assessment</p>		

6. Geology and Soils

Part 1	6.1	Is the scheme situated within or adjacent to a Geological SSSI or are there geological features within 2km?	No.
	6.2	Is the site located within a high risk area of contamination (historic landfills, agricultural/industrial landuse, brownfield sites etc)?	No
	6.3	Is a replanting scheme planned for the works?	No.
	6.4	Will there be land take outside the existing highways (displacement of soils)?	<i>Yes - minimise excavations/soil movements where possible.</i>
	6.5	If yes to 6.4, has the sustainable use of soil resources and other excavated materials been considered (i.e., the re-use of available soils within a site for the successful establishment of ground cover for landscape planting and habitat creation and transfer)?	<i>No - work with Environment Team to achieve the successful implementation of mitigation measures for the movement of excavated materials and soils.</i>
Design Team Notes – provide detail where possible			
6.4: Land take required in both options to facilitate widened shared use facility and separation strip.			
Part 2	Environment Team Assessment		

7. Material Assets and Waste

Part 1	7.1	Will waste (including soil arisings) be removed off site?	<i>Yes - sampling and testing in accordance with Milestone Sampling Plan for Waste Classification and Assessment – Scheme Works is required to be undertaken. The waste carrier and receiver must be licenced.</i>
	7.2	Is the scheme over £100,000 in value?	<i>No - discuss required waste measures with Environment Team to be included in the CEMP.</i>
	7.3	Is waste to be re-used, treated, recycled or stored on site?	<i>No</i>
	7.4	If yes, will it involve the re-use of more than 1000 tonnes of material?	Choose an item.
	7.5	Is any waste disposed of on third party land?	<i>No.</i>
	7.6	Will there be asphalt waste containing tarbound?	<i>Yes - consult Environment Team</i>
<p>Design Team Notes - provide a description of materials that will arise and quantities</p> <p>7.6: This project was for a Feasibility Design; therefore, no testing has yet been undertaken. Contam testing will be undertaken at prelim / detailed design prior to construction.</p>			
Part 2	Environment Team Assessment		

8. Noise and Vibration

Part 1	8.1	Will the scheme result in changes to the existing footprint (Dimensions, Surrounding Infrastructure, Traffic, Speeds, Parking, etc)?	<i>Yes - consider low noise materials or reduce the magnitude of changes to existing footprint. The impact on local sensitive receptors, where present, will need to be considered.</i>
	8.2	Will the scheme construction require night working, use of plant, equipment or methods (such as sheet piling) likely to result in disturbance to local residents?	No
	8.3	Will the Scheme require the use of a haul road &/or traffic diversion route?	No
<p>Design Team Notes – provide detail where possible (noise/vibration activities and information on equipment if an S61 is required)</p> <p>8.1: Land take required in both options, altering existing footprint dimensions. Existing parking bay to be removed.</p> <p>8.3: Traffic management is required in both options.</p>			
Part 2	Environment Team Assessment		

9. Population and Human Health (Effects on the Community)

Part 1	9.1	Are any aspects of the works likely to impact local residents, businesses or the local community (e.g. traffic management, closures, noise, visual aesthetic, air quality, Public Rights of Way)?	No
	9.2	Is the scheme situated on Common Land or Town & Village Green, or require land take beyond highways boundary (TVG)?	Yes - consent from planning inspectorate required.
	9.3	Will the works have any benefits to the community?	Yes - Please describe these in Design Team Notes below
<p>Design Team Notes – measures to reduce negative impacts on the community, provide detail where possible</p> <p>9.2: land take will be required where works sit outside of existing highway boundary, the landowners should be contacted regarding this.</p> <p>9.3 Existing shared use facility will be widened, with increase separation strip, which will improve safety & travel efficiency.</p>			
Part 2	<p>Environment Team Assessment</p>		

Hi

10. Road Drainage and the Water Environment

Part 1	10.1	Will there be works (including Ground Investigations and Vegetation Clearance pre-works & discharges) near a flood defence, on a floodplain or within 8m of an EA Main Riverbank?	No
	10.2	If yes to 10.1, do the works meet an Environment Agency Excluded Activity?	Choose an item.
	10.3	If no to 10.2, do the works meet an Environment Agency Flood Risk Exemption?	Choose an item.
	10.4	If no to 10.3, do the works meet one of the Environment Agency Standard Rules Permits?	Choose an item.
	10.5	If no to 10.4, are the works emergency/safety and/or are they going through planning?	Choose an item.
	10.6	If an exemption/permit is required, has an ecological assessment been undertaken?	No - consult Environment Team.
	10.7	Will there be works to or near any watercourses which are not EA Main River (drains, ditches, canal, discharges)?	No.
	10.8	Will there be an increase in hardstanding? This can impact runoff into drainage.	No
	10.9	Is the scheme located in a groundwater source protection zone?	No
Design team notes – for any Flood Risk Activity Permits, demonstrate how works satisfy the conditions of the exclusion or exemption			
Part 2	Environment Team Assessment		

11. Climate

Part 1	11.1	Has a carbon baseline been completed? The Highways England Tool contains carbon factors.	<i>No - estimate required materials (or use scheme BoQ) to complete a carbon baseline. This will help predict savings from lower carbon alternatives. Environment Team can assist.</i>
	11.2	Will construction greenhouse gas (GHG) emissions resulting from the Scheme increase by >1% (compared to the baseline scenario i.e. when compared to GHG emissions and energy use associated with existing maintenance activities)?	No
	11.3	During operation, will the scheme cause any of the following? <ul style="list-style-type: none"> > 10% change in Average Annual Daily Traffic (AADT). > 10% change to the number of heavy-duty vehicles. Daily average speed change of > 20 km/hr? 	No
	11.3	Is there potential for re-using and/or refurbishing existing assets to reduce the extent of new construction required?	<i>Yes - Please provide further details.</i>
	11.4	Is there potential for lower carbon options to deliver the project objectives (i.e., shorter routes with smaller construction footprints and low carbon plant)?	<i>Yes - Please provide further details.</i>
<p>Design Team Notes – provide detail why this design is the most favourable taking into consideration potential environmental impacts</p> <p>11.4: Potential use of electric plant reduces carbon, locally sourced materials, recycle waste material from excavation. Proposed asphalt to be warm mix. Potential for redundant path to be broken up (assuming uncontaminated) and re-used within sub-base of new pavement construction.</p>			
Part 2	Environment Team Assessment		

12. Opportunities

Part 1	12.1	Have more sustainable materials been considered (low carbon asphalt/concrete, Recycled Aggregate)?	<i>No – complete a carbon baseline with assistance from the Environment Team.</i>
	12.2	Schemes should be achieving a minimum biodiversity net gain of 10% (where applicable) - has this been considered in the design? The Biodiversity Tool can be used to calculate net gain. Guidance found here.	<i>No - consider using the biodiversity tool and measures such as replanting, reptile hibernacula, bird/bat boxes and wildlife kerbs. Environment Team can assist.</i>
	12.3	Is there opportunity to improve the operational performance of this design (e.g., design for lower embodied energy and emissions, electricity use due to street lighting and traffic lights, presumed maintenance, winter servicing, pollution prevention and leaching)?	<i>Yes - Please provide further details.</i>
	12.4	Has whole life cycle been considered in the design (i.e., design to deconstruct, material re-use and recycling at end of life, waste disposal)?	<i>No - Please provide further details.</i>
	12.5	The Whole Lifetime Costing (WLC) Tool can be used to calculate scheme cost and carbon over periods of up to 40 years. If the scheme requires asphalt, has the tool been considered? Guidance found here.	<i>No - consider using the WLC Tool to make a carbon/cost comparison over the project lifetime. Assistance from Pavement Engineer will be required.</i>
Design team notes - provide evidence of why opportunities cannot be considered in this design			
Part 2	Environment Team Assessment		

Consultees

Organisation:	Team / Individual:	Phone:	Email/Link	Consultation Required?
Milestone Infrastructure Ltd	Environment Team: Jackson Smith (Senior Design Advisor)	07824151792	Jackson.smith@milestoneinfra.co.uk	Yes
Cambridge City Council	Trees Officer	01223 457200	planning@greatercambridgeplanning.org	Yes
	Conservation Officer	01223 457200	planning@greatercambridgeplanning.org	Yes
South Cambridge District Council	Trees Officer	03450 455 215	planning.trees@scams.gov.uk	Choose an item.
	Conservation Officer	03450 455 215	Search by map - South Cambs District Council (scams.gov.uk)	Choose an item.
Fenland District Council	Trees Officer		trees@fenland.gov.uk	Choose an item.
	Conservation Officer		conservation@fenland.gov.uk	Choose an item.
Huntingdonshire District Council	Trees Officer	01480 388424	Huntingdonshire District Trees	Choose an item.
	Conservation Officer		Conservation Areas - Huntingdonshire.gov.uk	Choose an item.
East Cambridgeshire	Trees Officer	01353 616332	kevin.drane@eastcambs.gov.uk	Choose an item.
	Conservation Officer		christopher.partrick@eastcambs.gov.uk	Choose an item.
Environment Agency	Generic Contact (For notification)	03708 506 506	enquiries@environment-agency.gov.uk	Choose an item.
Natural England	Generic Contact (For notification)	03000603900	enquiries@naturalengland.org.uk	Choose an item.
Historic England	Generic Contact (For notification)	03703330607	customers@HistoricEngland.org.uk	Choose an item.
Forestry Commission (for Felling Licences)	Generic Contact (For notification)		info@forestryengland.uk	Choose an item.